

# RAIS<sup>®</sup> FLEX APPLICATORS

By Ransburg

**FOR DIRECT CHARGE  
WATER BASED APPLICATORS**



**MODEL: 81520 RFXw**

**IMPORTANT:** Before using this equipment, carefully read SAFETY PRECAUTIONS, starting on page 3, and all instructions in this manual. Keep this Service Manual for future reference.



# CONTENTS



<b>SAFETY:</b>	<b>3-7</b>
<a href="#">Safety Precautions</a> .....	3
<a href="#">Hazards / Safegaurds</a> .....	4
<b>ATEX/FM REQUIREMENTS:</b>	<b>8-13</b>
<a href="#">European ATEX Directive</a> .....	8
<a href="#">ATEX and FM Requirments</a> .....	9
<a href="#">RansFlex RFXw - Water Base Only</a> .....	10
<b>INTRODUCTION:</b>	<b>14-17</b>
<a href="#">General Description</a> .....	14
<a href="#">Ransflex New Features</a> .....	14
<a href="#">Specifications</a> .....	15
<a href="#">Typical Installation</a> .....	17
<b>INSTALLATION:</b>	<b>18-20</b>
<a href="#">81520 Ransflex Direct Charge Installation</a> .....	18
<a href="#">General Installation Requirements</a> .....	18
<a href="#">Waterborne Isolation System Installation Guidelines</a> .....	19
<a href="#">Applicator Installation</a> .....	19
<b>OPERATION:</b>	<b>21-27</b>
<a href="#">Applicator Operation</a> .....	21
<a href="#">Flushing / Color Change Procedure</a> .....	23
<a href="#">Fluid Nozzle / Air Cap</a> .....	24
<a href="#">New Nozzle Design</a> .....	24
<a href="#">Air Cap / Nozzle Performance</a> .....	27
<b>MAINTENANCE:</b>	<b>28-42</b>
<a href="#">Suitable Solvents For Cleaning RansFlex Applicators</a> .....	28
<a href="#">Routine Schedule</a> .....	29
<a href="#">Troubleshooting Guide</a> .....	42
<b>PARTS IDENTIFICATION:</b>	<b>43-58</b>
<a href="#">RansFlex RFXw Direct Charge Water Base</a> .....	43
<a href="#">Items for RFXw (65KV) Unit</a> .....	46
<a href="#">Handle Components For All Models</a> .....	48
<a href="#">Accessories</a> .....	56
<a href="#">Spare Parts Kits</a> .....	57
<a href="#">Recommended Spare Parts</a> .....	58



# SAFETY

## SAFETY PRECAUTIONS

Before operating, maintaining or servicing any Ransburg electrostatic coating system, read and understand all of the technical and safety literature for your Ransburg products. This manual contains information that is important for you to know and understand. This information relates to **USER SAFETY** and **PREVENTING EQUIPMENT PROBLEMS**. To help you recognize this information, we use the following symbols. Please pay particular attention to these sections.

### **WARNING**

**A WARNING!** states information to alert you to a situation that might cause serious injury if instructions are not followed.

### **CAUTION**

**A CAUTION!** states information that tells how to prevent damage to equipment or how to avoid a situation that might cause minor injury.

### **NOTE**

**A NOTE** is information relevant to the procedure in progress.

While this manual lists standard specifications and service procedures, some minor deviations may be found between this literature and your equipment. Differences in local codes and plant requirements, material delivery requirements, etc., make such variations inevitable. Compare this manual with your system installation drawings and appropriate Ransburg equipment manuals to reconcile such differences.



Careful study and continued use of this manual will provide a better understanding of the equipment and process, resulting in more efficient operation, longer trouble-free service and faster, easier troubleshooting. If you do not have the manuals and safety literature for your Ransburg system, contact your local Ransburg representative or Ransburg.





### **WARNING**



- The user **MUST** read and be familiar with the Safety Section in this manual and the Ransburg safety literature therein identified.
- This equipment is intended to be used by trained personnel **ONLY**.
- This manual **MUST** be read and thoroughly understood by **ALL** personnel who operate, clean or maintain this equipment! Special care should be taken to ensure that the **WARNINGS** and safety requirements for operating and servicing the equipment are followed. The user should be aware of and adhere to **ALL** local building and fire codes and ordinances as well as **NFPA-33 AND EN 50176 SAFETY STANDARDS, LATEST EDITION**, or applicable country safety standards, prior to installing, operating, and/or servicing this equipment.



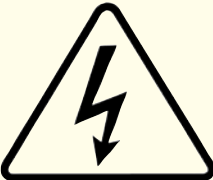

### **WARNING**

- The hazards shown on the following pages may occur during the normal use of this equipment. Please read the hazard chart beginning on page 2.

<p><b>AREA</b> Tells where hazards may occur.</p>	<p><b>HAZARD</b> Tells what the hazard is.</p>	<p><b>SAFEGUARDS</b> Tells how to avoid the hazard.</p>
<p><b>Spray Area</b></p>  	<p><b>Fire Hazard</b></p> <p>Improper or inadequate operation and maintenance procedures will cause a fire hazard.</p> <p>Protection against inadvertent arcing that is capable of causing fire or explosion is lost if any safety interlocks are disabled during operation. Frequent Power Supply or Controller shutdown indicates a problem in the system requiring correction.</p>	<p>Fire extinguishing equipment must be present in the spray area and tested periodically.</p> <p>Spray areas must be kept clean to prevent the accumulation of combustible residues.</p> <p>Smoking must never be allowed in the spray area.</p> <p>The high voltage supplied to the atomizer must be turned off prior to cleaning, flushing or maintenance.</p> <p>Spray booth ventilation must be kept at the rates required by NFPA-33, OSHA, country, and local codes. In addition, ventilation must be maintained during cleaning operations using flammable or combustible solvents.</p> <p>Electrostatic arcing must be prevented. Safe sparking distance must be maintained between the parts being coated and the applicator. A distance of 1 inch for every 10KV of output voltage is required at all times.</p> <p>Test only in areas free of combustible material. Testing may require high voltage to be on, but only as instructed.</p> <p>Non-factory replacement parts or unauthorized equipment modifications may cause fire or injury. If used, the key switch bypass is intended for use only during setup operations. Production should never be done with safety interlocks disabled.</p> <p>The paint process and equipment should be set up and operated in accordance with NFPA-33, NEC, OSHA, local, country, and European Health and Safety Norms.</p> 

<p><b>AREA</b> Tells where hazards may occur.</p>	<p><b>HAZARD</b> Tells what the hazard is.</p>	<p><b>SAFEGUARDS</b> Tells how to avoid the hazard.</p>
<p><b>Spray Area</b></p> 	<p><b>Explosion Hazard</b></p> <p>Improper or inadequate operation and maintenance procedures will cause a fire hazard.</p> <p>Protection against inadvertent arcing that is capable of causing fire or explosion is lost if any safety interlocks are disabled during operation.</p> <p>Frequent Power Supply or Controller shutdown indicates a problem in the system requiring correction.</p>	<p>Electrostatic arcing must be prevented. Safe sparking distance must be maintained between the parts being coated and the applicator. A distance of 1 inch for every 10KV of output voltage is required at all times.</p> <p>Unless specifically approved for use in hazardous locations, all electrical equipment must be located <b>outside</b> Class I or II, Division 1 or 2 hazardous areas, in accordance with NFPA-33.</p> <p>Test only in areas free of flammable or combustible materials.</p> <p>The current overload sensitivity (if equipped) <b>MUST</b> be set as described in the corresponding section of the equipment manual. Protection against inadvertent arcing that is capable of causing fire or explosion is lost if the current overload sensitivity is not properly set. Frequent power supply shutdown indicates a problem in the system which requires correction.</p> <p>Always turn the control panel power off prior to flushing, cleaning, or working on spray system equipment.</p> <p>Before turning high voltage on, make sure no objects are within the safe sparking distance.</p> <p>Ensure that the control panel is interlocked with the ventilation system and conveyor in accordance with NFPA-33, EN 50176.</p> <p>Have fire extinguishing equipment readily available and tested periodically.</p>
<p><b>General Use and Maintenance</b></p>  	<p>Improper operation or maintenance may create a hazard.</p> <p>Personnel must be properly trained in the use of this equipment.</p>	<p>Personnel must be given training in accordance with the requirements of NFPA-33, EN 60079-0.</p> <p>Instructions and safety precautions must be read and understood prior to using this equipment.</p> <p>Comply with appropriate local, state, and national codes governing ventilation, fire protection, operation maintenance, and housekeeping. Reference OSHA, NFPA-33, EN Norms and your insurance company requirements.</p> 

<p><b>AREA</b> Tells where hazards may occur.</p>	<p><b>HAZARD</b> Tells what the hazard is.</p>	<p><b>SAFEGUARDS</b> Tells how to avoid the hazard.</p>
<p><b>Spray Area / High Voltage Equipment</b></p>  	<p><b>Electrical Discharge</b></p> <p>There is a high voltage device that can induce an electrical charge on ungrounded objects which is capable of igniting coating materials.</p> <p>Inadequate grounding will cause a spark hazard. A spark can ignite many coating materials and cause a fire or explosion.</p>	<p>Parts being sprayed and operators in the spray area must be properly grounded.</p> <p>Parts being sprayed must be supported on conveyors or hangers that are properly grounded. The resistance between the part and earth ground must not exceed 1 meg ohm. (Refer to NFPA-33.)</p> <p>Operators must be grounded. Rubber soled insulating shoes should not be worn. Grounding straps on wrists or legs may be used to assure adequate ground contact.</p> <p>Operators must not be wearing or carrying any ungrounded metal objects.</p> <p>When using an electrostatic handgun, operators must assure contact with the handle of the applicator via conductive gloves or gloves with the palm section cut out.</p> <p><b>NOTE: REFER TO NFPA-33 OR SPECIFIC COUNTRY SAFETY CODES REGARDING PROPER OPERATOR GROUNDING.</b></p> <p>All electrically conductive objects in the spray area, with the exception of those objects required by the process to be at high voltage, must be grounded. Grounded conductive flooring must be provided in the spray area.</p> <p>Always turn off the power supply prior to flushing, cleaning, or working on spray system equipment.</p> <p>Unless specifically approved for use in hazardous locations, all electrical equipment must be located <b>outside</b> Class I or II, Division 1 or 2 hazardous areas, in accordance with NFPA-33.</p> <p>Avoid installing an applicator into a fluid system where the solvent supply is ungrounded.</p> <p>Do not touch the applicator electrode while it is energized.</p> 

<p><b>AREA</b> Tells where hazards may occur.</p>	<p><b>HAZARD</b> Tells what the hazard is.</p>	<p><b>SAFEGUARDS</b> Tells how to avoid the hazard.</p>
<p><b>Electrical Equipment</b></p> 	<p><b>Electrical Discharge</b></p> <p>High voltage equipment is utilized in the process. Arcing in the vicinity of flammable or combustible materials may occur. Personnel are exposed to high voltage during operation and maintenance.</p> <p>Protection against inadvertent arcing that may cause a fire or explosion is lost if safety circuits are disabled during operation.</p> <p>Frequent power supply shut-down indicates a problem in the system which requires correction.</p> <p>An electrical arc can ignite coating materials and cause a fire or explosion.</p>	<p>Unless specifically approved for use in hazardous locations, the power supply, control cabinet, and all other electrical equipment must be located outside Class I or II, Division 1 and 2 hazardous areas in accordance with NFPA-33 and EN 50176.</p> <p>Turn the power supply OFF before working on the equipment.</p> <p>Test only in areas free of flammable or combustible material.</p> <p>Testing may require high voltage to be on, but only as instructed.</p> <p>Production should never be done with the safety circuits disabled.</p> <p>Before turning the high voltage on, make sure no objects are within the sparking distance.</p>
<p><b>Toxic Substances</b></p> 	<p><b>Chemical Hazard</b></p> <p>Certain materials may be harmful if inhaled, or if there is contact with the skin.</p>	<p>Follow the requirements of the Safety Data Sheet supplied by coating material manufacturer.</p> <p>Adequate exhaust must be provided to keep the air free of accumulations of toxic materials.</p> <p>Use a mask or respirator whenever there is a chance of inhaling sprayed materials. The mask must be compatible with the material being sprayed and its concentration. Equipment must be as prescribed by an industrial hygienist or safety expert, and be NIOSH approved.</p>
<p><b>Spray Area</b></p>  	<p><b>Explosion Hazard — Incompatible Materials</b></p> <p>Halogenated hydrocarbon solvents for example: methylene chloride and 1,1,1,-Trichloroethane are not chemically compatible with the aluminum that might be used in many system components. The chemical reaction caused by these solvents reacting with aluminum can become violent and lead to an equipment explosion.</p>	<p>Spray applicators require that aluminum inlet fittings be replaced with stainless steel.</p> <p>Aluminum is widely used in other spray application equipment - such as material pumps, regulators, triggering valves, etc. Halogenated hydrocarbon solvents must never be used with aluminum equipment during spraying, flushing, or cleaning. Read the label or data sheet for the material you intend to spray. If in doubt as to whether or not a coating or cleaning material is compatible, contact your coating supplier. Any other type of solvent may be used with aluminum equipment.</p> 



## EUROPEAN ATEX DIRECTIVE 2014/34/EU



The following instructions apply to equipment covered by certificate number Sira 14ATEX 5343:

1. The equipment may be used with flammable gases and vapors with apparatus groups II and with temperature class T6.
2. The equipment is only certified for use in ambient temperatures in the range +5°C to +40°C and should not be used outside this range.
3. Installation shall be carried out by suitably trained personnel in accordance with the applicable code of practice e.g. EN 60079-14:1997.
4. Inspection and maintenance of this equipment shall be carried out by suitably trained personnel in accordance with the applicable code of practice e.g. EN 60079-17.
5. Repair of this equipment shall be carried out by suitable trained personnel in accordance with the applicable code of practice e.g. EN 60079-19.
6. Putting into service, use, assembling, and adjustment of the equipment shall be fitted by suitably trained personnel in accordance with the manufacturer's documentation.

Refer to the "Table of Contents" of this service manual:

- a. Installation
  - b. Operation
  - c. Maintenance
  - d. Parts Identification
7. Components to be incorporated into or used as replacement parts of the equipment shall be fitted by suitably trained personnel in accordance with the manufacturer's documentation.

8. The certification of this equipment relies upon the following materials used in its construction:

If the equipment is likely to come into contact with aggressive substances, then it is the responsibility of the user to take suitable precautions that prevent it from being adversely affected, thus ensuring that the type of protection provided by the equipment is not compromised.

Aggressive substances: e.g. acidic liquids or gases that may attack metals, or solvents that may affect polymeric materials.

Suitable precautions: e.g. regular checks as part of routine inspections or establishing from the material's data sheets that it is resistant to specific chemicals.

Refer to "Specifications" in the "Introduction" section:

- a. All fluid passages contain stainless steel or nylon fittings.
  - b. High voltage cascade is encapsulated with a solvent resistant epoxy.
9. A recapitulation of the certification marking is detailed in the "ATEX" section, on the next page, drawing number: 80777-11 and 80777-12.
  10. The characteristics of the equipment shall be detailed e.g. electrical, pressure, and voltage parameters.

**The manufacturer should note that, on being put into service, the equipment must be accompanied by a translation of the instructions in the language or languages of the country in which the equipment is to be used and by the instructions in the original language.**



# ATEX REQUIREMENTS

## ATEX Requirements

This product provides a direct charge to water based materials that will improve the transfer efficiency over non-electrostatic products. Because it is direct charge, the fluid delivery system must be isolated from ground to allow proper electrostatic charging of the fluid.

# FM REQUIREMENTS

## Requirements

These applicators are FM approved when the product setup is configured to drawings shown on the following pages. This product is approved for use only with non-flammable water-based materials when the materials meet the FM definition for a waterbased spray material\*. It is the end users' responsibility to insure the material that is sprayed meets this requirement.

\* FM 7260 waterbased spray material - a material that does not sustain burning when tested in accordance with ASTM D 4206.



80777-11

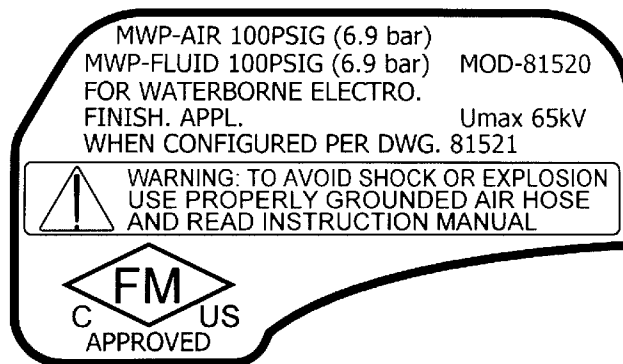

80777-12



## RANSFLEX RFX<sub>w</sub> - WATER BASE ONLY

**81520 - ABC0EF**

Base Model No.	Optional Designations
-------------------	--------------------------

(Ordering Information Only)



CONFIGURATION DWG. 81521-00  
REV. A



“R” (Air Cap)



“S” (Fluid Nozzle)



“T” (Pressure Reducer)



### ATOMIZATION - TABLE OF “A” DASHES

“A” Dash No.	“A” Description	“R”	“S”	“T”
0	V SERIES 1.2mm	80265-00	80264-12	79809-00
1	V SERIES 1.4mm	80265-00	80264-14	79809-00
2	V SERIES 1.8mm	80265-00	80264-18	79809-00
3	C SERIES 1.2mm	80231-00	80230-12	79809-03
4	C SERIES 1.4mm	80231-00	80230-14	79809-03
5	C SERIES 1.8mm	80231-00	80230-18	79809-03
6	T SERIES 1.2mm	80240-00	80239-12	74963-05
7	T SERIES 1.4mm	80240-00	80239-14	74963-05
8	T SERIES 1.8mm	80240-00	80239-18	74963-05
9	ROUND SPRAY	79962-00	80400-00	74963-05



80775-01 “U”



80775-00 “U”

### FLUID CONTROL - TABLE OF “B” DASHES

“B” Dash No.	“B” Description	“U”
1	ADJUSTABLE FLUID	80775-00
2	NON-ADJUSTABLE FLUID	80775-01



“V”

### TRIGGER - TABLE OF “C” DASHES

“C” Dash No.	“C” Description	“V”
1	2 FINGER TRIGGER	80211-00
2	4 FINGER TRIGGER	80386-00
3	2 FINGER SMALL PROFILE	80566-00



### FLUID HOSE - TABLE OF "E" DASHES

"E" Dash No.	"E" Description	"X"
0	NO FLUID HOSE	---
1	3/16 ID, 10m	80500-10
2	3/16 ID, 15m	80500-15
3	1/4 ID, 10m	80501-10
4	1/4 ID, 15m	80501-15

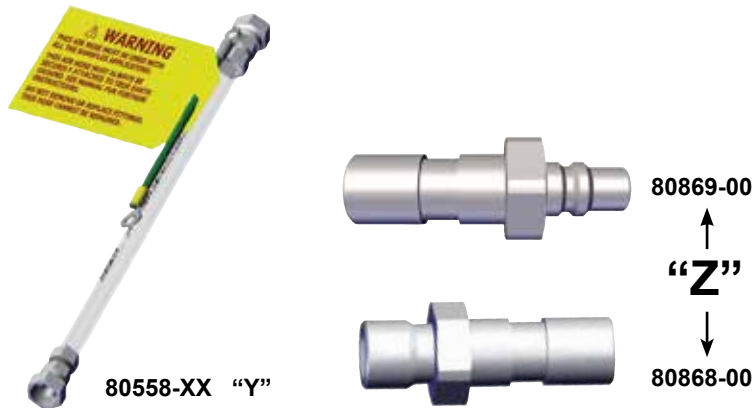

### AIR HOSE - TABLE OF "F" DASHES

"F" Dash No.	"F" Description	"Y"	"Z"
0	NO AIR HOSE, STANDARD	---	80868-00
1	STANDARD AIR HOSE, 5m	80558-05	80868-00
2	STANDARD AIR HOSE, 10m	80558-10	80868-00
3	STANDARD AIR HOSE, 15m	80558-15	80868-00
4	STANDARD AIR HOSE, 20m	80558-20	80868-00
5	NO AIR HOSE, QD	---	80869-00
6	QD AIR HOSE, 10m	80558-06	80869-00
7	QD AIR HOSE, 10m	80558-11	80869-00
8	QD AIR HOSE, 15m	80558-16	80869-00
9	QD AIR HOSE, 20m	80558-21	80869-00



### AVAILABLE ACCESSORIES

Part #	Description	For Use With	Nozzle Color
80264-07	V SERIES 0.7mm	80265-00	Black
80264-10	V SERIES 1.0mm	80265-00	Black
80239-07	T SERIES 0.7mm	80240-00	Black
80239-10	T SERIES 1.0mm	80240-00	Black



# INTRODUCTION

## GENERAL DESCRIPTION

The **Ransflex** is an air atomizing applicator powered only by a pressurized air source. Pressurized air creates rotation of a turbine generator that powers a cascade. The cascade generates a high voltage DC charge to the electrode creating an electrostatic field between the atomizer and the target.

One of the many features of the Ransflex applicator system is that the electrical energy, which is available from the resistive charging electrode, is limited to the optimum level of safety and efficiency. The system is incapable of releasing sufficient electrical or thermal energy during normal operating conditions to cause ignition of specific hazardous materials in their most easily ignited concentrations in air.

As the applicator electrode approaches ground, applicator circuitry causes the high voltage to approach zero while the current approaches its maximum value. This performance is validated by independent test agencies that give ATEX EN 50050 approvals or FM 7260 approvals.

This Ransflex model is designed specifically for direct charge waterbase applications only. The waterborne fluid supply system must be isolated from ground to allow proper electrostatic charging of the fluid.

The water base materials must be classified as non-flammable spray material. This means the mixture with air cannot be ignited by an energy source less than 500 mJ.

## RANSFLEX NEW FEATURES

- Light weight and easy to maneuver.
- Ergonomic handle design to reduce operator fatigue.
- Three phases of turbine protection:
  - Divorced turbine air supply cartridge
  - Sealed nozzle/Atomization passages
  - Strategic turbine location
- DeVilbiss spray technology integration into atomization.
- Simultaneous fan/atom pressure adjustment with compensation valve.



## SPECIFICATIONS: 81520 RANSFLEX DIRECT CHARGE WATERBASE

### Environmental/Physical

<b>Applicator Length:</b>	273mm (10.75 inches)
<b>Weight: (Without Hose)</b>	620 grams (22 oz.)
<b>Hose 80558-XX Lengths (Std):</b>	5m, 10m, 15m and 20m

### Electrical

<b>Operating Voltage:</b>	65kV DC (-) maximum
<b>Current Output:</b>	120 microamperes maximum
<b>Paint Resistance:*</b>	Water base paint only
<b>Part Sprayability:</b>	Determine sprayability of part to be coated using 76652, Test Equipment

(See current "Paint, HV & SCI Test Equipment" service manual TE-98-01)

\* Use Model No. 76652, Test Equipment

### Mechanical

<b>Fluid Flow Capacity:</b>	1000 ml/minute**
<b>Wetted Parts:</b>	Stainless, polyethylene, nylon, acetal polymer
<b>Operating Pressure (Air Spray)</b>	
<b>Fluid:</b>	(0-6.9 bar) 0-100 psi
<b>Air:</b>	(0-6.9 bar) 0-100 psi
<b>Ambient Temp.:</b>	40°C to 5°C (104°F to 32°F)
<b>Consumption (With Voltage):</b>	438 SLPM (15.4 SCFM) @ 2.8 bar (40 psig) @ Handle Inlet
<b>Sound Level:</b>	92dB (A) @ 2.8 bar (40 psig) Inlet, 1m from applicator

\*\* This reflects the maximum fluid volume the applicator can deliver. The maximum spray volume that can be effectively atomized depends on fluid rheology, spray technology, and finish quality required.



Figure 1: RansFlex Water Base Direct Charge Electrostatic Spray Applicator 81520

**RANSFLEX WATER BASE DIRECT CHARGE ELECTROSTATIC SPRAY APPLICATOR 81520**

No.	Description	No.	Description
1	Needle/Electrode	7	Exhaust Air Hose
2	Barrel	8	Waterborne Fluid Hose
3	Handle	9	Voltage On/Off Switch
4	Fan Adjustment	10	Trigger
5	Fluid Adjustment	11	Compensation Valve
6	Air Hose	12	Air Cap / Fluid Nozzle

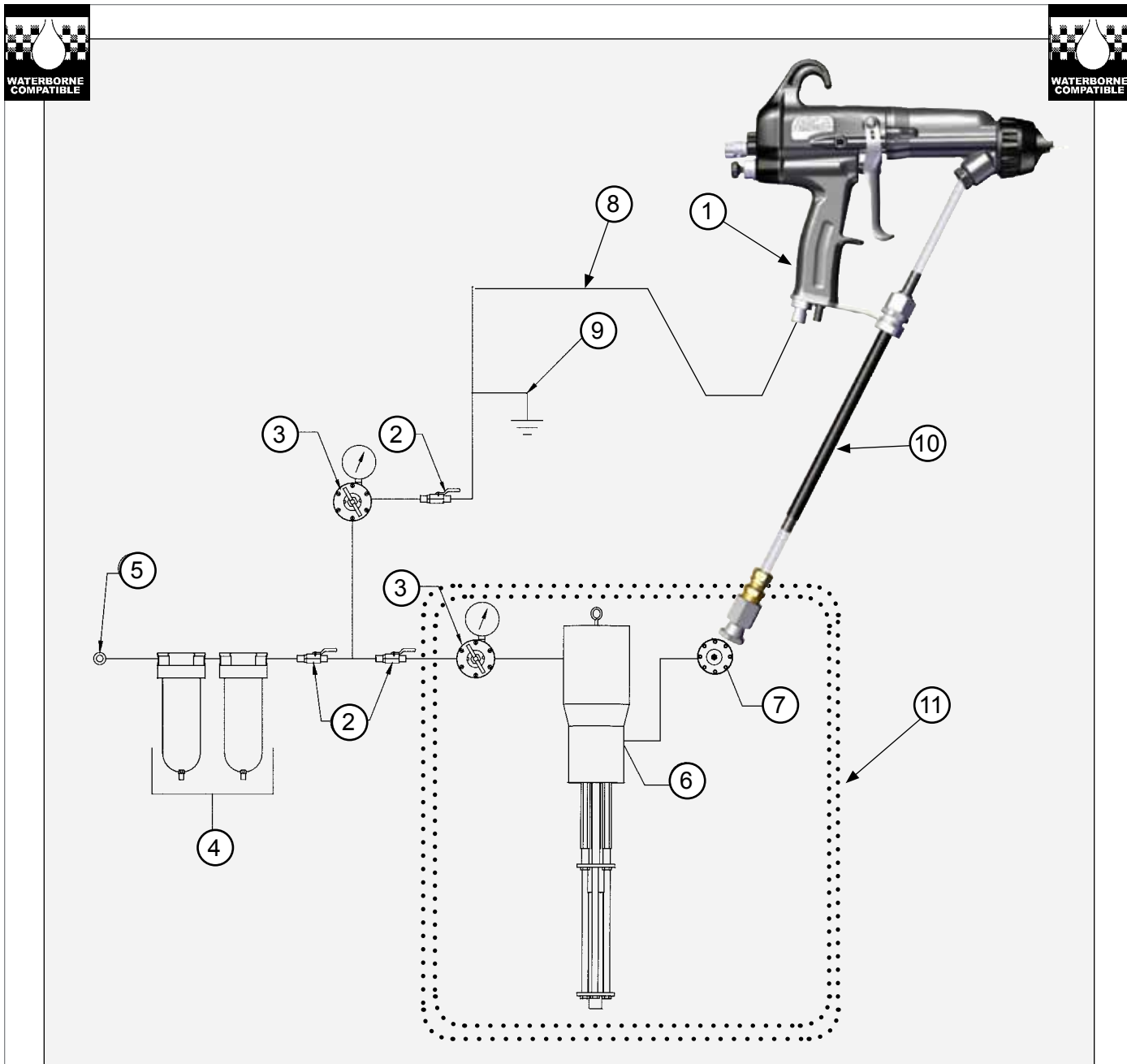

Figure 2: RansFlex Typical Waterborne Installation

**RANSFLEX WATERBORNE TYPICAL INSTALLATION**

No.	Description	No.	Description
1	RansFlex 81520	7	Fluid Regulator
2	Ball Valve	8	Air Hose (80558-XX)
3	Air Regulator with Pressure Gauge	9	Air Hose Ground Wire
4	Air / Water Separator	10	Isolated Waterborne Hose
5	Main Air Supply Line	11	Voltage Isolation / Protection
6	Fluid Supply (Grounded)		



# INSTALLATION

## Air Hose

**WARNING**

- For proper safe function of the applicator and operator the 80558-XX Air Hose Assembly must be used (either standard or quick disconnect style).

## Filters

1. Install an air filter assembly on the outlet of the main air regulator. The filter should be 5 micron with a maximum working pressure of at least 100 psig (6.9 bar). For Class 3 air quality, which is a 5 micron size and has a dew point of -4°F (-20°C), the relative humidity (RH) of the air should be 5%.
2. Ransburg recommends that a fluid filter be installed at the output of the fluid supply (pressure pot, pump, circulating system, etc.). It is the end user's responsibility to install the proper filter that meets their system's requirements.

## 81520 RANSFLEX DIRECT CHARGE INSTALLATION

**WARNING**

- The user **MUST** read and be familiar with the "Safety" section of this manual.
- This hand held device is intended to be used by trained personnel **ONLY**.
- This manual **MUST** be read and thoroughly understood by **ALL** personnel who operate, clean, or maintain this equipment! Special care should be taken to ensure that the warnings and requirements for operating and servicing safely are followed. The user should be aware of and adhere to **ALL** local building and fire codes and ordinances as well as NFPA, OSHA, and all related country safety codes prior to installing, operating, and/or servicing this equipment.
- Personnel **MUST** be **GROUNDING** to prevent a shock or spark during electrostatic operation.
- Install and route the hoses so they are **NOT** exposed to temperatures in excess of 120° F (49° C) and so that all hose bends are **NO LESS** than a 6-inch (15cm) radius. Failure to comply with these parameters could cause equipment malfunction that might create **HAZARDOUS CONDITIONS!**

## GENERAL INSTALLATION REQUIREMENTS

1. Operator must make skin contact with handle of applicator. If gloves are required use either gloves with palm and finger cut out or conductive gloves. See accessory pages for conductive gloves.

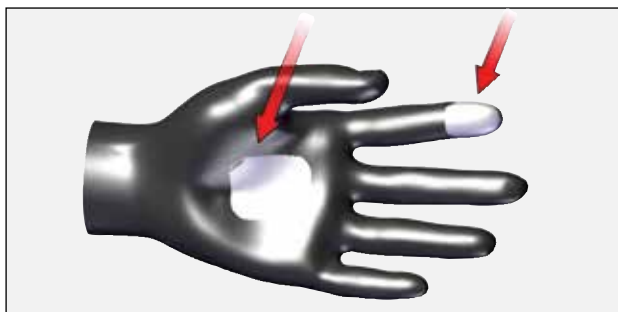



- All objects inside spray area must be grounded - reference EN 50 176 and/or NFPA-33. Resistance to earth ground must be less than 1 meg Ohm.

### Interlocks Required

Interlock the solvent supply with the main supply air to the applicator. When solvent is On, main supply air to the applicator is Off. Interlocks are user supplied.

### WARNING

- The solvent supply must be interlocked with applicator supply air.

## WATERBORNE ISOLATION SYSTEM INSTALLATION GUIDELINES

### WARNING

- Typical installation to spray non-flammable conductive materials (waterborne materials) must not be used to handle flammable materials (solvent based materials).

Using waterborne coating with electrostatic equipment requires that the fluid source be isolated from ground. Precautions should be taken to ensure operation safety and system efficiency. The following guidelines should be followed:

- The fluid lines and source MUST be isolated from ground. An isolating Paint Stand or similar isolating (non-porous) material MUST be used.
- Isolation stands MUST be at least 18-inches from grounded booth walls, chain link fences, or other grounded objects.
- Air hoses to the pressure pot or pump on the insulating stand should be non-conductive plastic. Many rubber hoses will have static grounding circuits or carbon content and are NOT suitable for this application.
- All charged (isolated) systems MUST be inside a fence or cage to prevent contact by personnel. An interlock system MUST be provided that interrupts high voltage flow to the applicator if the gate is opened.



- Air regulations for pots or pumps should be mounted remotely outside the fence or cage area to facilitate changes in pressure without shutting the system down.
- Grounding hooks at the cage MUST be used to ground the system when personnel are working close by.
- Fluid lines to the applicator MUST be protected from scraping and abrasion on the floor or sharp metal edges that could lead to voltage pin holing and loss of kV on the charged system.
- Cleanliness and maintenance are extremely critical.

## APPLICATOR INSTALLATION

- Ensure there is a true earth ground connection available. Connect the air hose ground to this connection.

### WARNING

- The air hose ground must be connected to true earth ground.

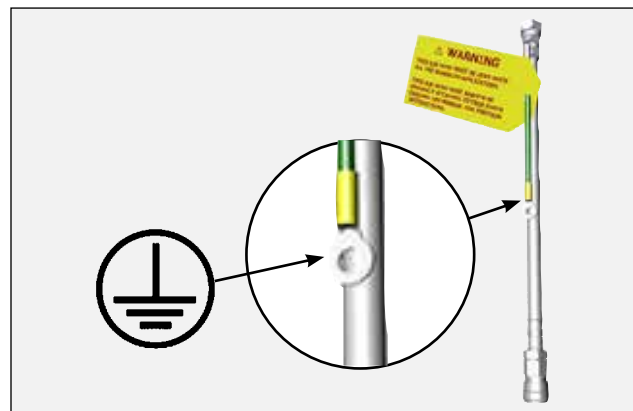

- Turn off power.





3. Connect air.



**OR...**

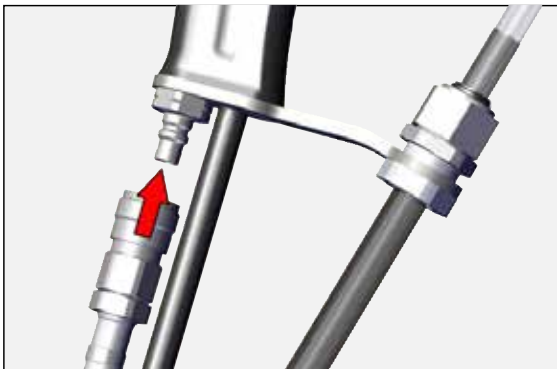

- 4. Trigger applicator with fluid off. Look for leaks in any connections.
- 5. Activate fluid, check for leaks with solvent flush if required.



# OPERATION

## APPLICATOR OPERATION

1. Set fluid pressure using flow regulator, insure voltage is discharged from system.

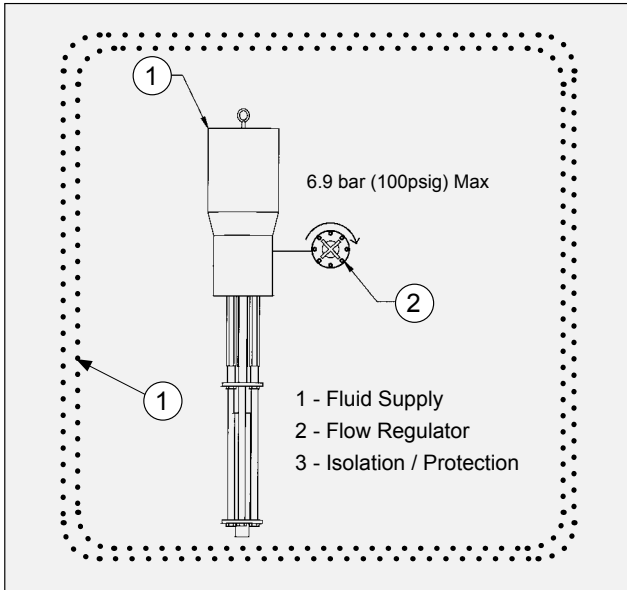

2. Disconnect the air to the applicator.

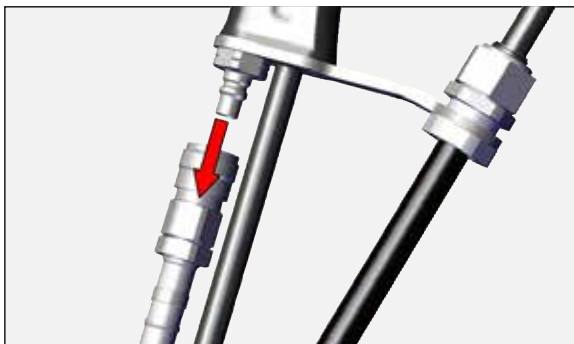

OR...



3. Activate trigger to start material stream into grounded metal bucket or suitable area.

**! WARNING**

➤ The bucket or area sprayed into must be grounded to true earth ground.



4. Release trigger stop material flow.



5. Re-connect air supply.



OR...





- 6. Adjust air pressure.
- 7. Position air cap to achieve pattern direction.
- 8. Actuate applicator (with voltage off) to spray test pattern.
- 9. As a guide, the tables below show a pressure at the wall to give 2.7 bar (40 psig) dynamic at the handle of the applicator with different hose lengths.
- 10. Turn on voltage and trigger applicator. Green light should be on.

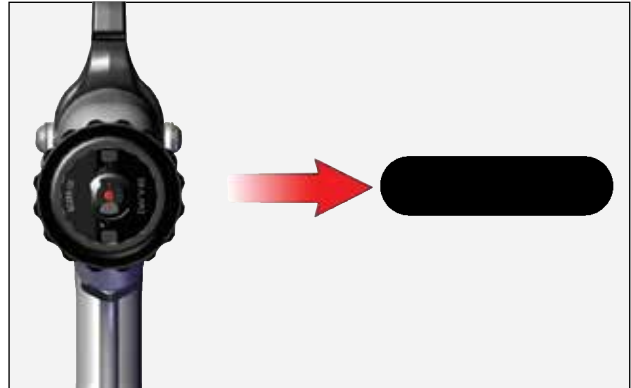

(Horns Vertical)



- 11. Adjust fluid pressure and air pressure as required to achieve finish.
- 12. Adjust air cap position as required.

- 13. Adjust fan pattern as required.

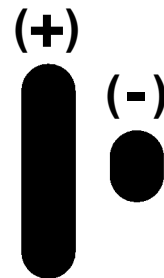

(Horns Horizontal)

- 14. Adjust fluid flow.

**NOTE**

➤ It is recommended fluid flow be controlled by the supply regulator. This adjustment should only be used for fine adjustments.

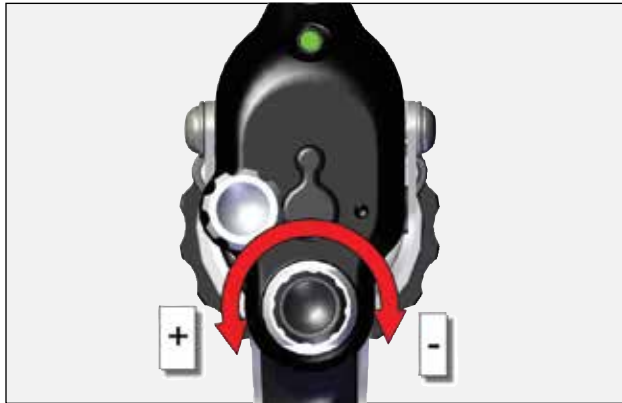

15. Adjust compensation valve with small driver.

**NOTE**

► The compensation valve adjustment is used to adjust fan and atomization pressure at the same time when the pressure to run the turbine is higher than the atomization fan pressure desired.

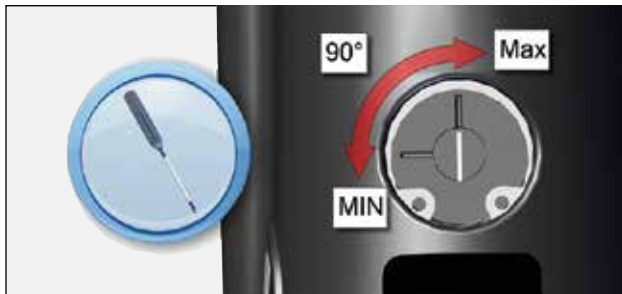

### FLUSHING / COLOR CHANGE PROCEDURE

1. Turn off electrostatics.



**! WARNING**

► The solvent supply must be interlocked with the applicator supply air.

2. Disconnect air to applicator.

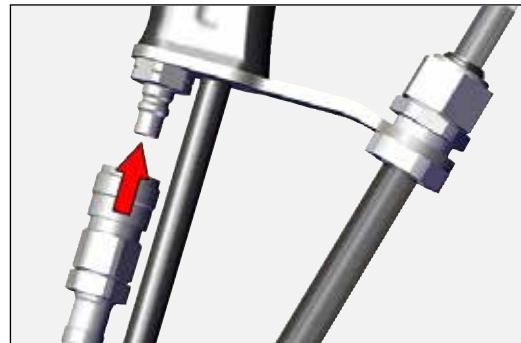

OR...

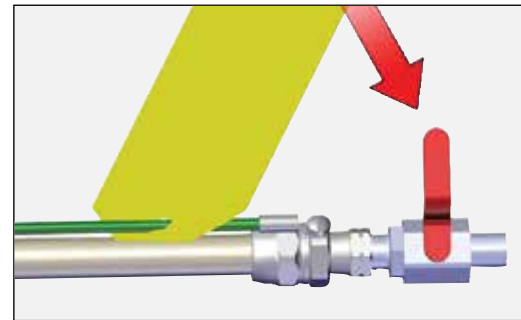

3. Discharge fluid into appropriate earth grounded metal container

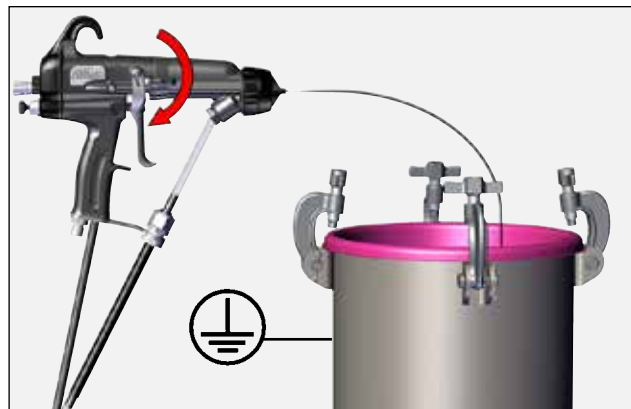

4. Load next color, solvent flush and/or remove applicator from installation as required.



## FLUID NOZZLE / AIR CAP

The fluid nozzle and air cap must be selected according to the application. The following charts show the nozzles and air caps available for the RansFlex.

**⚠ CAUTION**

➤ Nozzles from previous Ransburg design are not compatible with the Ransflex design. Use of these nozzles could cause equipment malfunction and possible damage.



## NEW NOZZLE DESIGN

With the release of the RansFlex applicator a new configuration of nozzles was also released.

- Red nozzles - 1.2 mm I.D.
- Grey nozzles - 1.4 mm I.D.
- Green nozzles - 1.8 mm I.D.
- All other accessory sizes are black

### C-31 AIR CAP 80231-00

80558-XX Length	Static Pressure at Wall		Dynamic Pressure at Wall	
	bar	psig	bar	psig
20 m	3.7	53	3.4	50
15 m	3.6	52	3.3	48
10 m	3.5	50	3.2	47

### T-40 AIR CAP 80240-00

80558-XX Length	Static Pressure at Wall		Dynamic Pressure at Wall	
	bar	psig	bar	psig
20 m	4.3	62	3.9	57
15 m	4.1	60	3.8	55
10 m	4.0	58	3.7	53



**V-65 AIR CAP 80265-00**

80558-XX Length	Static Pressure at Wall		Dynamic Pressure at Wall	
	bar	psig	bar	psig
20 m	4.1	60	3.9	56
15 m	4.0	59	3.7	54
10 m	3.8	55	3.6	52

To identify the nozzle, each is engraved with the air cap it must be paired up with.



**NOZZLE SELECTION 80265-00 / 80264-XX**

Nozzle Part Number	For Use With Air Cap P/N	Color	Nozzle Opening
80264-07	80265-00	Black	0.7 mm
80264-10	80265-00	Black	1.0 mm
80264-12	80265-00	Red	1.2 mm
80264-14	80265-00	Grey	1.4 mm
80264-18	80265-00	Green	1.8 mm

**HIGH WEAR NOZZLE SELECTION 80265-00 / 80464-XX**

Nozzle Part Number	For Use With Air Cap P/N	Color	Nozzle Opening
80464-14	80265-00	Tan	1.4 mm
80464-18	80265-00	Tan	1.8 mm

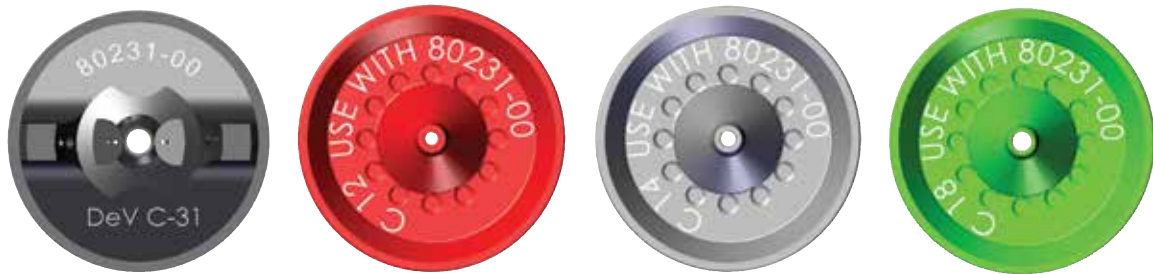

**80231-00 / 80230-XX C SERIES**

Nozzle Part Number	For Use With Air Cap P/N	Color	Nozzle Opening
80230-12	80231-00	Red	1.2 mm
80230-14	80231-00	Grey	1.4 mm
80230-18	80231-00	Green	1.8 mm



**80240-00 / 80239-XX T SERIES**

Nozzle Part Number	For Use With Air Cap P/N	Color	Nozzle Opening
80239-07	80240-00	Black	0.7 mm
80239-10	80240-00	Black	1.0 mm
80239-12	80240-00	Red	1.2 mm
80239-14	80240-00	Grey	1.4 mm
80239-18	80240-00	Green	1.8 mm



## AIR CAP / NOZZLE PERFORMANCE

### V-65 - 80265-00

Nozzle	Orifice ID (mm/in)	*Fluid Delivery (ml/min)	Spray Type	Pattern Length (mm/in)	Pattern Width (mm/in)	Pressure Reducer
80264-12	1.2/.047	250	Air Spray	355/14.0	76/3.0	79809-00 (Yellow)
80264-14	1.4/.055	250	Air Spray	343/13.5	76/3.0	79809-00 (Yellow)
80264-18	1.8/.070	250	Air Spray	267/10.5	76/3.0	79809-00 (Yellow)

### C-31 - 80231-00

Nozzle	Orifice ID (mm/in)	*Fluid Delivery (ml/min)	Spray Type	Pattern Length (mm/in)	Pattern Width (mm/in)	Pressure Reducer
80230-12	1.2/.047	250	Air Spray	350/14.0	76/3.0	79809-03 (White)
80230-14	1.4/.055	250	Air Spray	330/13.0	76/3.0	79809-03 (White)
80230-18	1.8/.070	250	Air Spray	280/11.0	76/3.0	79809-03 (White)

### T-40 - 80240-00

Nozzle	Orifice ID (mm/in)	*Fluid Delivery (ml/min)	Spray Type	Pattern Length (mm/in)	Pattern Width (mm/in)	Pressure Reducer
80239-12	1.2/.047	250	LVMP	330/13.0	76/3.0	74963-05 (Black)
80239-14	1.4/.055	250	LVMP	310/12.2	76/3.0	74963-05 (Black)
80239-18	1.8/.070	250	LVMP	292/11.5	76/3.0	74963-05 (Black)

\* Material: Enamel 24 sec. No. 4 Ford Cup @ 23° C (72°F).  
Results are material dependent.

\*\* Patterns are at 200mm (8") target distance.



# MAINTENANCE

## SUITABLE SOLVENTS FOR CLEANING RANSFLEX APPLICATORS

When cleaning the applicator, a suitable solvent for cleaning depends on the part(s) of the applicator to be cleaned and the material that needs to be removed. Ransburg recommends that all exterior cleaning be done with non-polar solvents to prevent a conductive residue on critical components. We also understand that some of these solvents do not always meet the cleaning needs of some materials. **If conductive polar solvents are used to clean the applicator components, all residue must be removed using a non-conductive non-polar solvent (i.e. high flash Naphtha).** If there are any questions as to what solvents are best for cleaning, contact your local Ransburg distributor and/or your paint supplier.

The RansFlex applicator, air hoses and fluid hose, should not be submerged or soaked in solvent. However, the outer surfaces of these items can be wiped with a suitable cleaning solvent.

**⚠ CAUTION**

- All electrical components **cannot** be cleaned or soaked in any solvents.

Please reference Solvent Selection Guide TL-15-01 for detailed information on solvent polarity. (Reference [www.ransburg.com](http://www.ransburg.com))

**⚠ WARNING**

- The user **MUST** read and be familiar with the safety instructions in this manual.
- If compressed air is used in cleaning, **REMEMBER** that high pressure air can be dangerous and should **NEVER** be used against the body. It can blind, deafen, and may even penetrate the skin. If used for cleaning equipment, the user should wear safety glasses.
- Be **SURE** the applicator power is **OFF** and the system is grounded before using solvent to clean **ANY** equipment.
- **DO NOT** operate a faulty applicator!
- When using cleaning solvent, standard health and safety precautions should apply.
- Any solvent used to clean the fluid passages must be discharged into a grounded container. Use of ungrounded or plastic containers may cause fire or explosion.

**⚠ CAUTION**

- Cleaning of the exterior surface of the applicator should be done with non-polar solvents. If cleaning requires the use of polar solvents, the applicator should be wiped down with non-polar solvent prior to going back into use. Using polar solvents will leave a semi-conductive film on the surface of the applicator that will effect efficiency of the applicator and cause damage to the components.



**⚠ CAUTION**

➤ Nozzles from previous Ransburg design are not compatible with the Ransflex design. Use of these nozzles could cause equipment malfunction and possible damage.

**⚠ WARNING**

➤ The flash point of the cleaning solvent shall be at least 15° C (27° F) above the ambient temperature. Otherwise, the cleaning process must be carried out in an area with forced air ventilation. It is the end users responsibility to insure this condition is met.

All repairs should be made on a clean, flat surface. If a vise is used to hold parts during service or repair, DO NOT clamp onto plastic parts and always pad the vise jaws!

The following parts should be thoroughly packed with dielectric grease (LSCH0009-00) leaving **NO** air space or voids when assembling:

- All O-Rings (PTFE o-rings do not need lubrication)
- Needle Shaft Assembly
- Packing Tube
- Cascade and Barrel

**Equipment Required**

- Special Multi-Purpose Wrench (80353-00)\*
- Hex Driver (79862-02)\*
- Dielectric Grease (LSCH0009-00)\*
- 10 mm Wrench
- 15 mm Wrench
- Spanner

\* Supplied with applicator

**ROUTINE SCHEDULE**

Follow these maintenance steps to extend the life of the applicator and ensure efficient operation:

**Several Times Daily**

Inspect the air cap for paint accumulation. Clean as frequently as necessary with a soft bristled brush and a suitable solvent.

**⚠ CAUTION**

➤ **NEVER** remove the fluid nozzle assembly while paint is in the applicator or paint may enter into the air passages. Clogged or restricted air passages will cause poor atomization and/or electrical shorting. Air passages that are clogged with conductive material can lead to excessive current output levels and consequent low operating voltage or long-term electrical damage.

The applicator barrel **MUST** be tilted front down to remove the fluid nozzle. Failure to do so may allow paint to enter the air passages, thereby reducing airflow and damaging the applicator barrel/cascade. Applicators may be flushed in lieu of tilting. However, they must be either flushed or tilted down during nozzle removal!

**Cleaning Flushing**

1. Reference page 18 and 19 for flushing procedure. Flushing should be performed at the end of daily use or prior to any maintenance.
2. Applicator exterior cleaning at the end of each shift, wipe the outside of the applicator with a solvent soaked rag pointing the applicator nose down. (Use non-polar solvents)

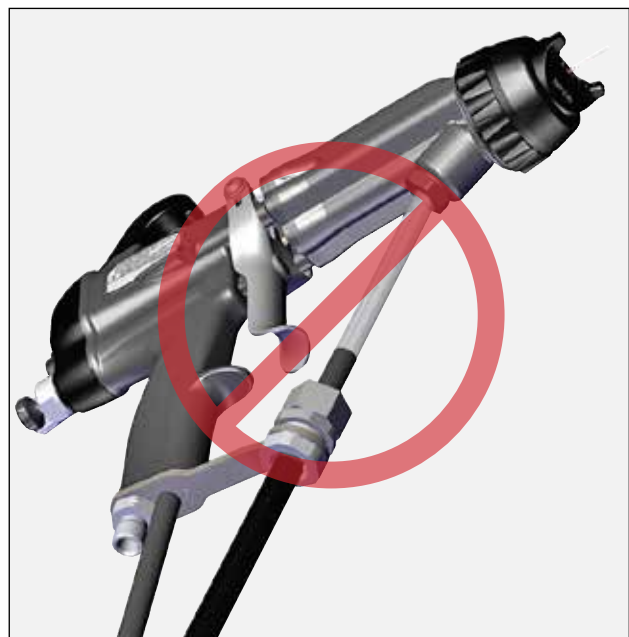

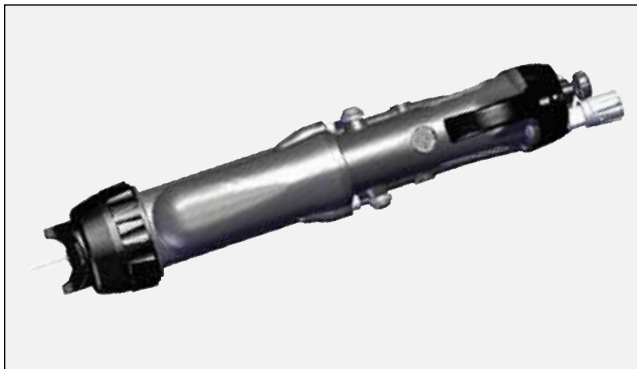

## NOTE

► Standard electrode is "snap back" spray wire electrode.

- Straighten the applicator electrode if necessary.
- Clean the fluid filter, if used.

## Bi-Yearly

- Check air hose resistance. If resistance is greater than 0.5 MegOhm the hose should be replaced.

## WARNING

► It is the end users responsibility to insure the 0.5 MegOhm to ground condition is met.

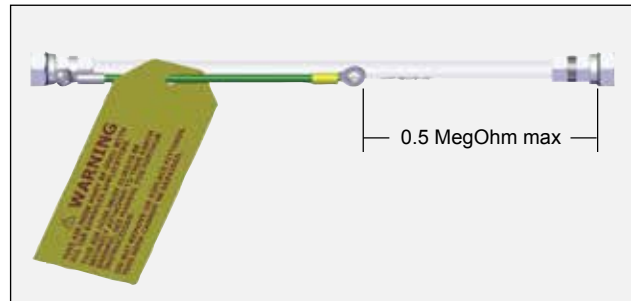

- On quick disconnect units check qd function. If worn replace hose assembly.

## Air Cap Removal

1. Remove retaining ring and air cap.

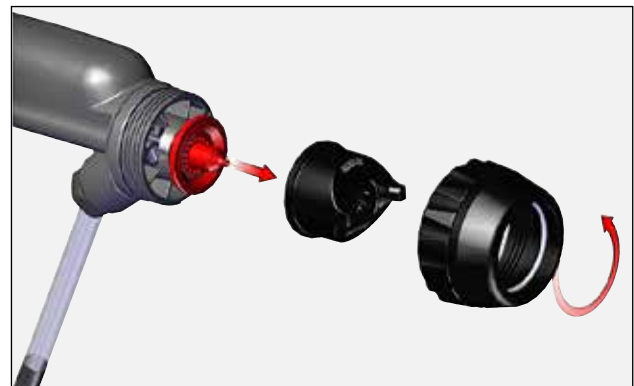

## Daily (or at start of each shift)

- Verify that ALL solvent safety containers are grounded!
- Check within 6m (20-ft.) of the point of operation (of the applicator) and remove or ground ALL loose or ungrounded objects.
- Inspect work holders for accumulated coating materials (and remove such accumulations).
- Check that atomizer assembly is clean and undamaged.



- 2. Clean and replace as necessary.
- 3. Install in reverse order.

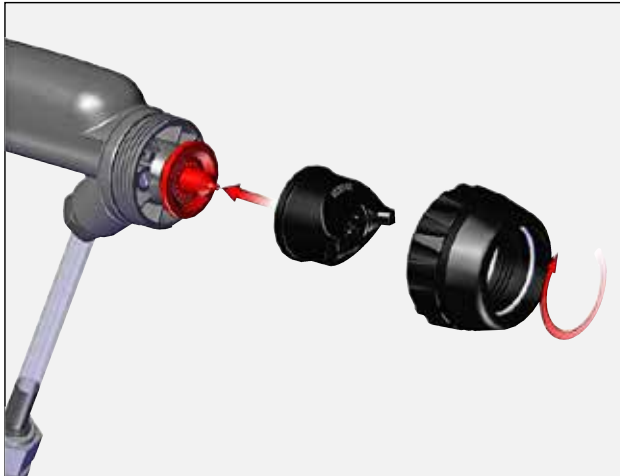

**Fluid Nozzle Removal**

**⚠ WARNING**

- Prior to removing the fluid nozzle, all pressure from the system must be relieved.

- 1. Insert 80353-00 wrench onto nozzle flats.

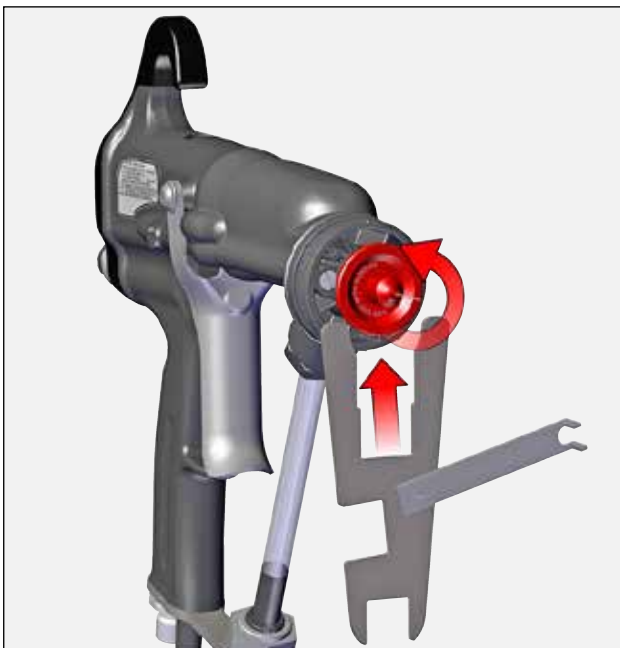

- 2. O-ring in barrel, replace as required.



- 3. Install fluid nozzle using 80353-00 wrench. Tighten till nozzle seats on O-ring and then 1/8 additional turn.



**NOTE**

- Do not over tighten. Fan pattern reduction will be effected

**Barrel Removal**

- 1. Remove trigger.





2. Remove fluid tube.



3. Pull barrel away.

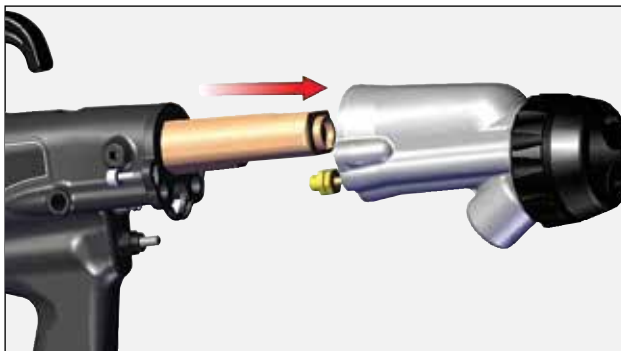

### Remove/Replace Cascade

1. Pull cascade straight out.

**⚠ CAUTION**

- Do not pull with excessive force or twist wires. This could damage cascade connector or wire harness.



2. Carefully disconnect harness by pulling connector on both sides by hand and rocking it side to side to remove.

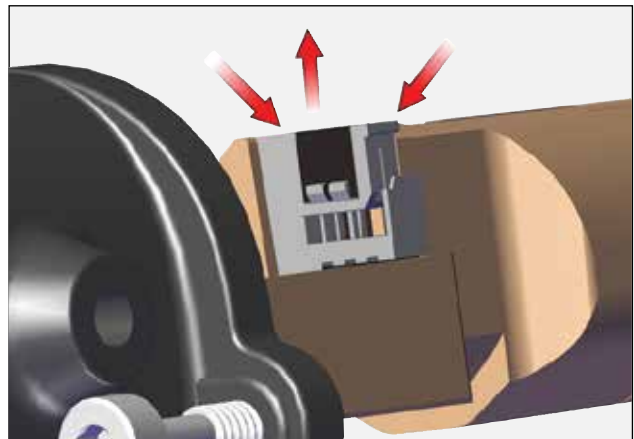

3. Replace cascade as necessary.

4. Apply LSCH 0009 grease to end of cascade.

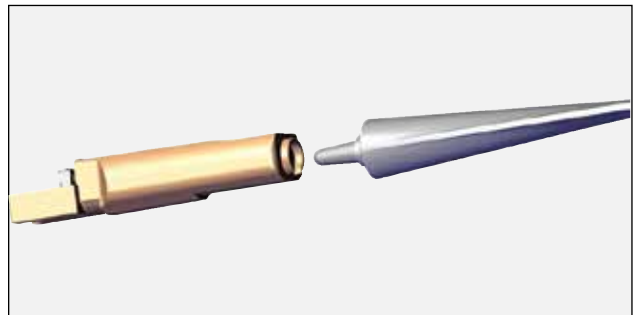

5. Re-connect harness by pushing down to snap.



6. Re-install cascade into handle.



### Packing Removal/Replace

1. Remove barrel from handle.
2. Use 80353 wrench to remove nut.

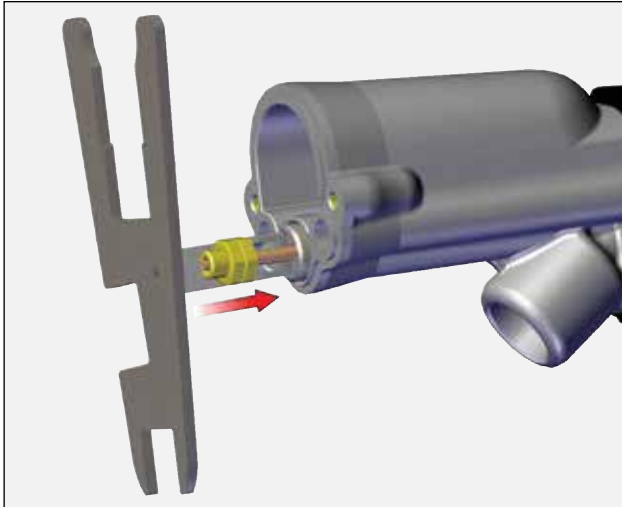

3. Pull straight out of barrel.

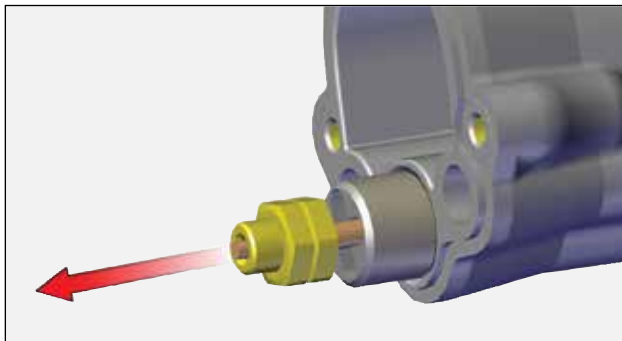

4. Remove jam nuts using 10mm wrench.

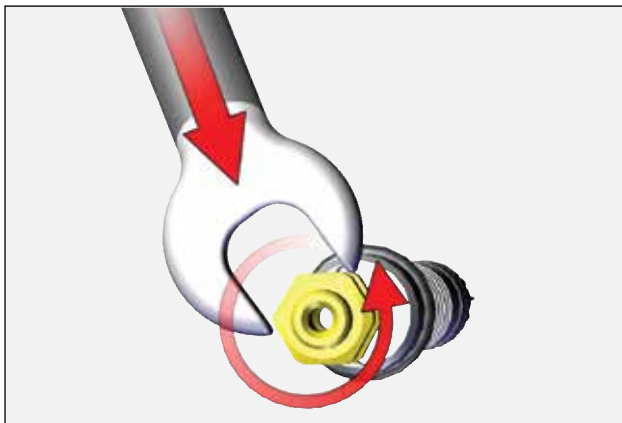

5. Remove all parts, clean with non-polar solvent. Inspect for any discolored areas. Replace parts as required.

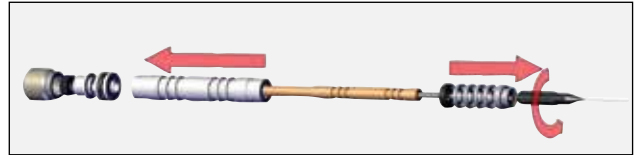

6. Prior to installation apply dielectric grease inside packing tube, completely full.

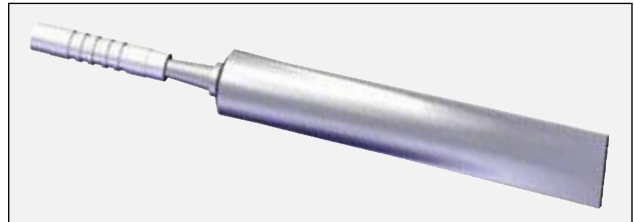

7. Insert parts on front of shaft.



8. Insert packing tube onto shaft. Wipe excess grease over front parts and outside of packing tube.

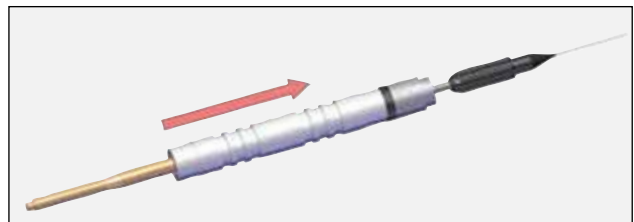

9. Install rear parts.





10. Install Bellville washers in sequence shown.

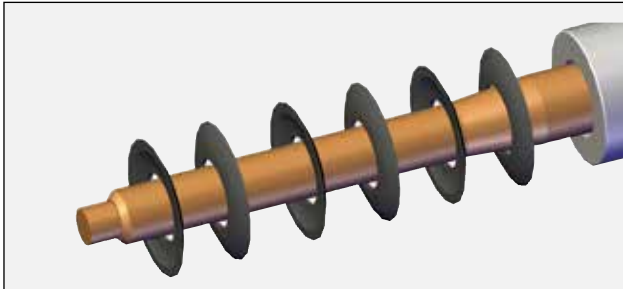

11. Install rear nut. Install jam nuts finger tight.

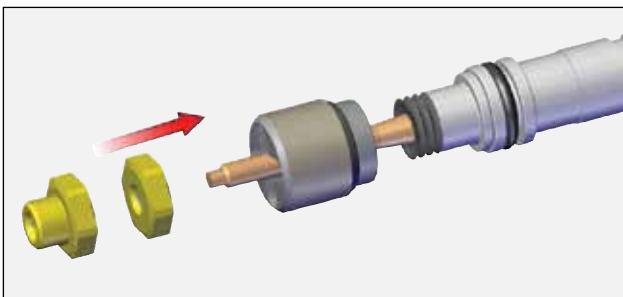

12. Set air before fluid adjustment.



13. Tighten jam nuts.

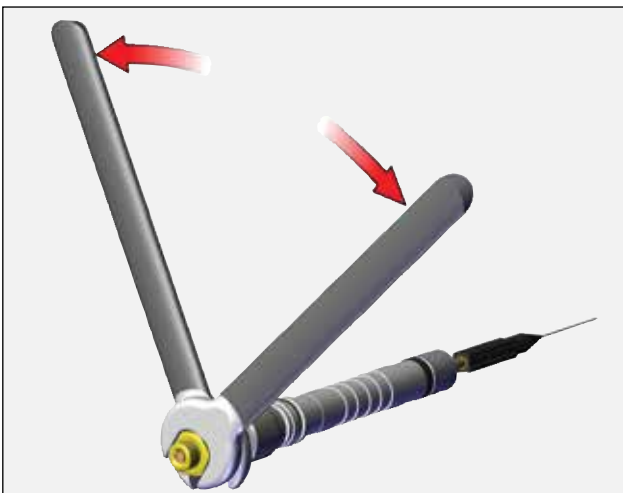

### Re-Install Needle Shaft Into Barrel

1. Install needle shaft into barrel with die-electric grease.

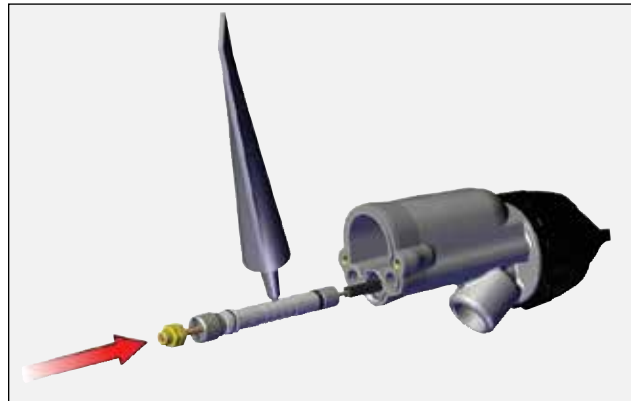

2. Tighten packing using wrench. Pull back and forth on the needle shaft till a slight amount of drag is felt.

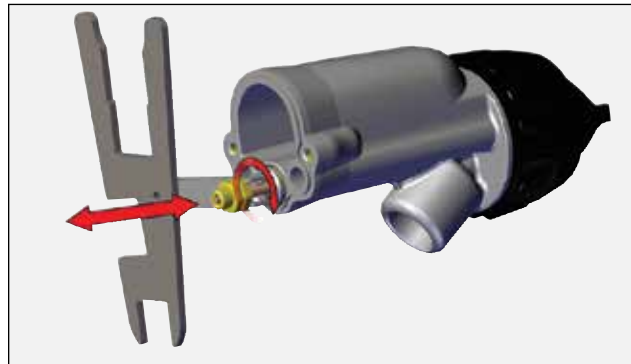

3. Squeeze approximately 1/3 tube of LSCH0009-00 dielectric grease in the cascade pocket.





### Re-Install Barrel

1. Install barrel over cascade.

#### NOTE

► The gasket between the handle and barrel is reusable. It should only be replaced if torn or damaged.

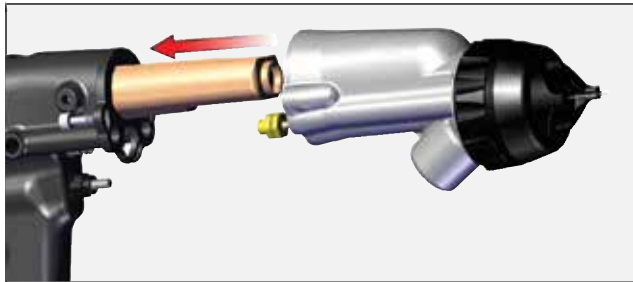

2. Tighten barrel screws.



3. Re-install fluid tube.



4. Re-install trigger.



### Rear Cover/Motor Module Repair

1. Loosen cover screw with 3mm driver.



2. Remove fan air cartridge with 10mm wrench.



3. Remove rear cover and cartridge with 15mm wrench.

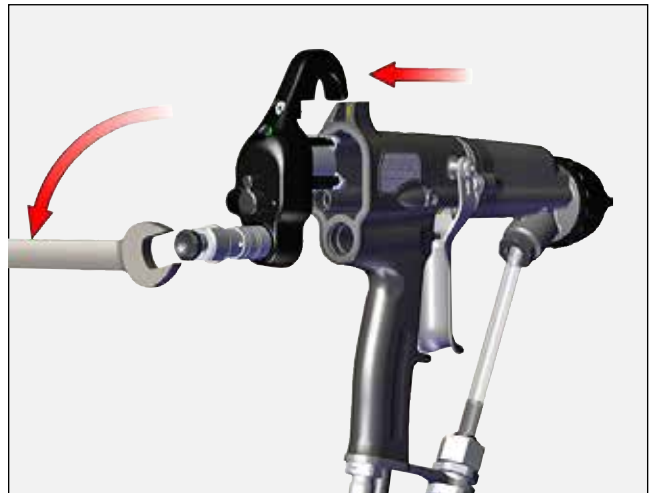

4. Disconnect motor connector from handle wire harness connector and remove rear cartridge.



### Motor Removal

1. Remove light pipe.



2. Remove screw and retainer.

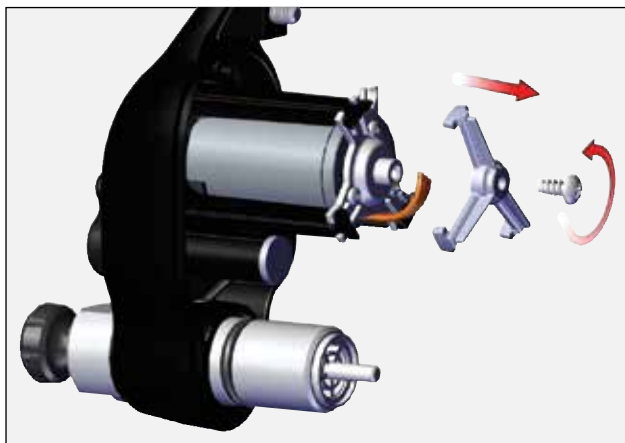

3. Remove motor assembly by pulling out on 3 arms, pull motor out.

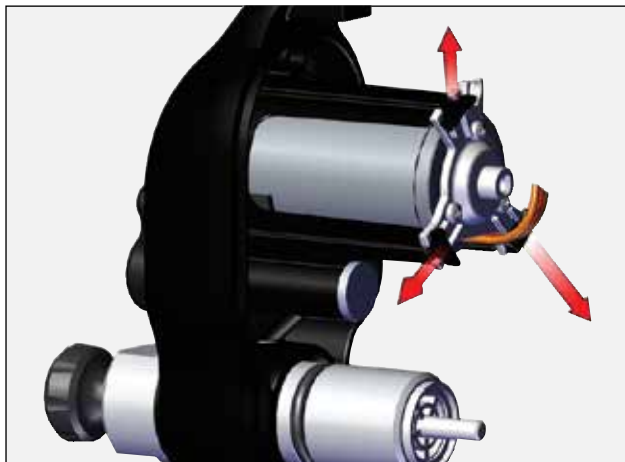

4. Remove porting block.



**NOTE**

- Block must be pulled out with fingers rocking the part side to side while pulling.

**NOTE**

- Only remove fluid valve cartridge if parts are being changed.

5. Remove fluid valve cartridge O-ring.

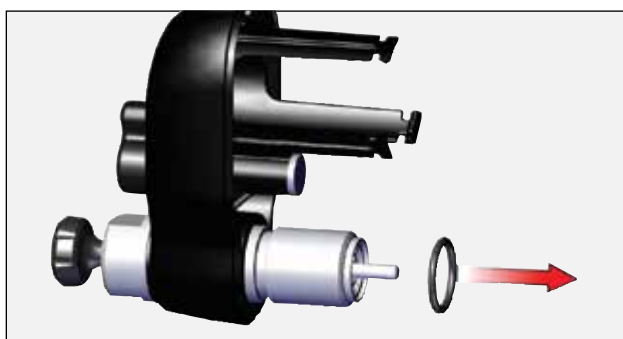

6. Push on edges to remove fluid valve cartridge.

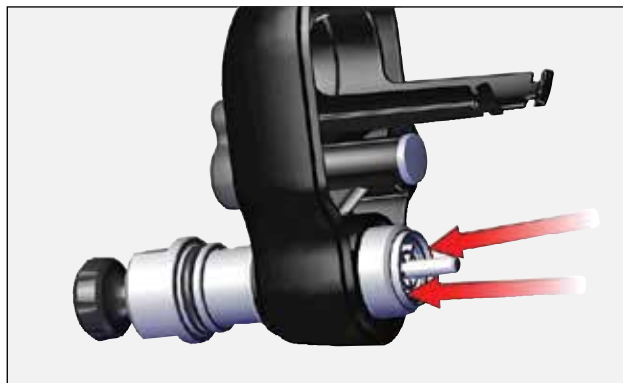



### Re-assembly

1. Install porting block on motor. Align screw heads into porting recess.

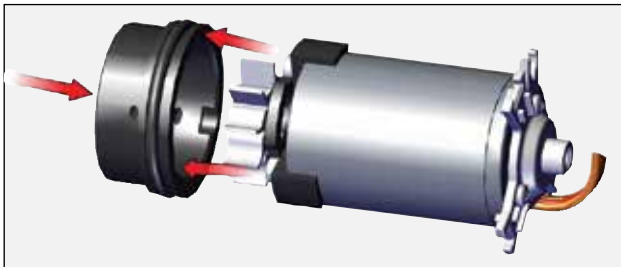

2. Align motor slots with 3 tab arms.

**NOTE**

- There is only one way to install the motor.

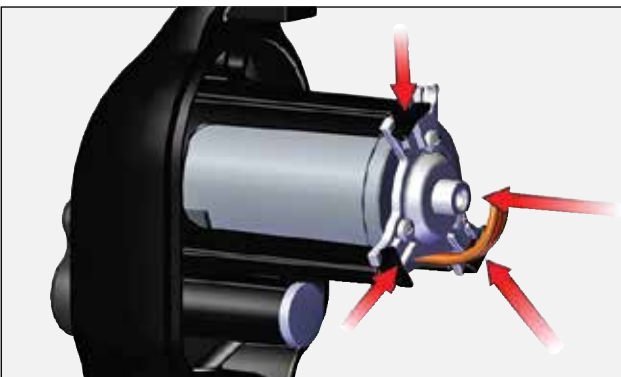

3. Install cartridge then o-ring (if removed).

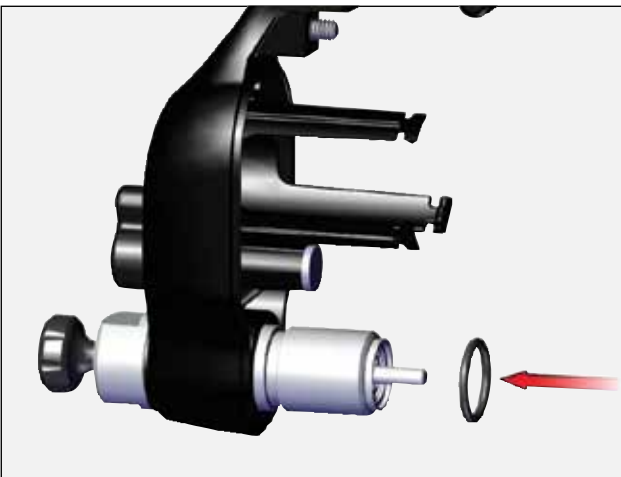

4. Install screw and retainer.

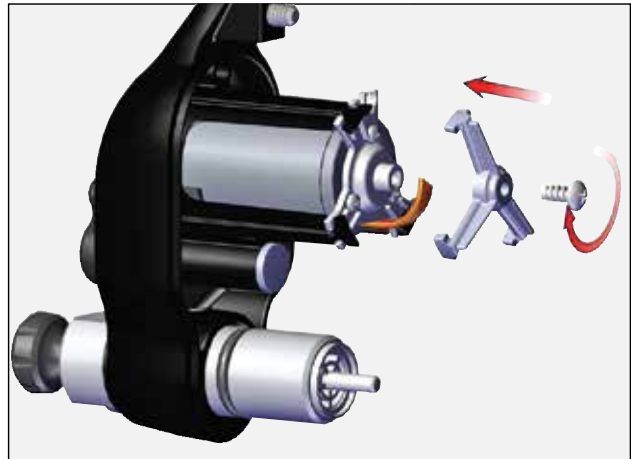

**NOTE**

- Only one way to position

5. Install light pipe.

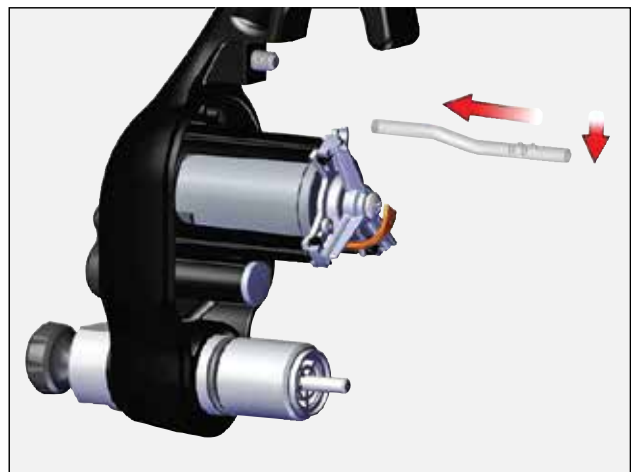

**CAUTION**

- When re-assembling the rear cover carefully insert the wires so they are not pinched during re-assembly.



6. Install gasket and re-connect motor connector to handle harness connector.

**NOTE**  
➤ This gasket is reusable. It should only be replaced if torn or damaged.

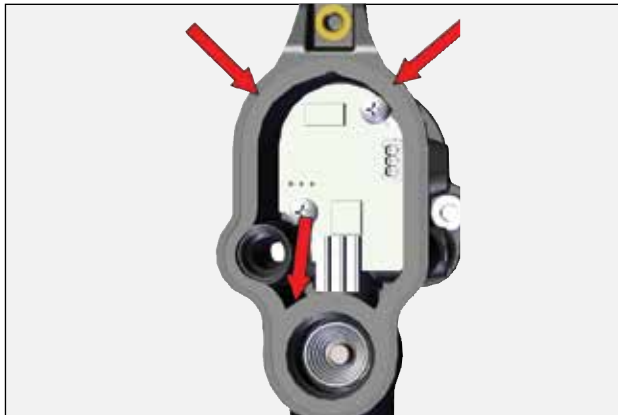

7. Push rear cover assembly into handle and tighten cartridge.

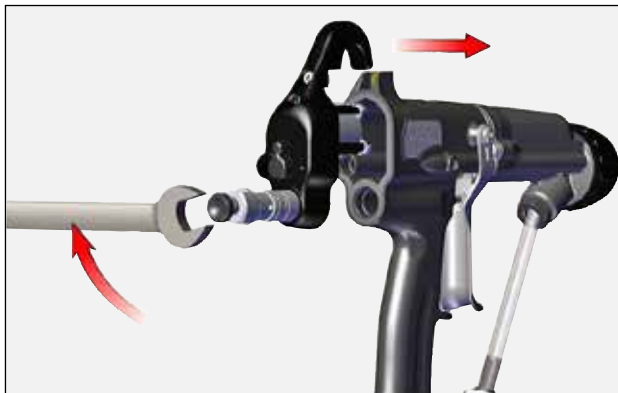

8. Install fan air valve cartridge.

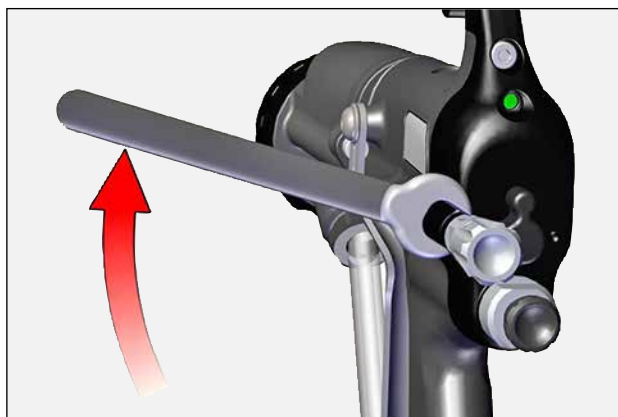

9. Tighten cover screw.



### Air Valve Remove/Replace

1. Remove trigger.
2. Remove rear cover assembly.
3. Remove air valve and spring.



4. Remove air valve packing nut and packing.

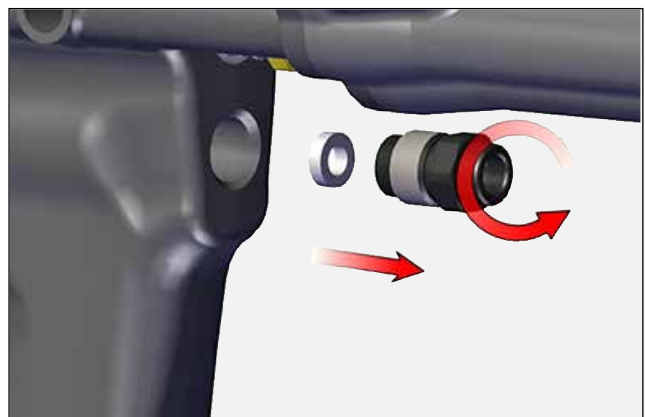



5. Insert air valve and spring.



2. Remove air fitting.

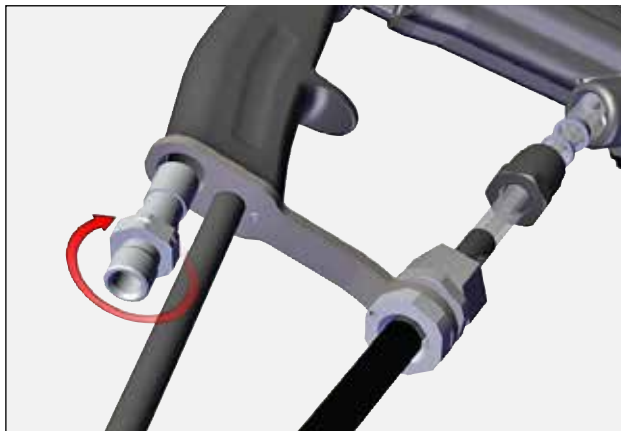

6. Tighten packing nut till light drag is felt on the shaft while moving it back and forth.

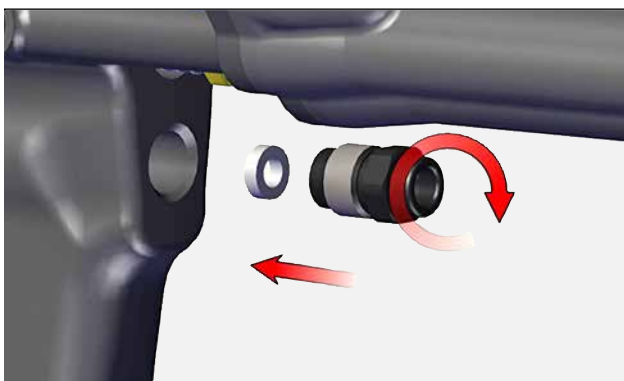

3. Remove bracket, gasket and hose assembly.

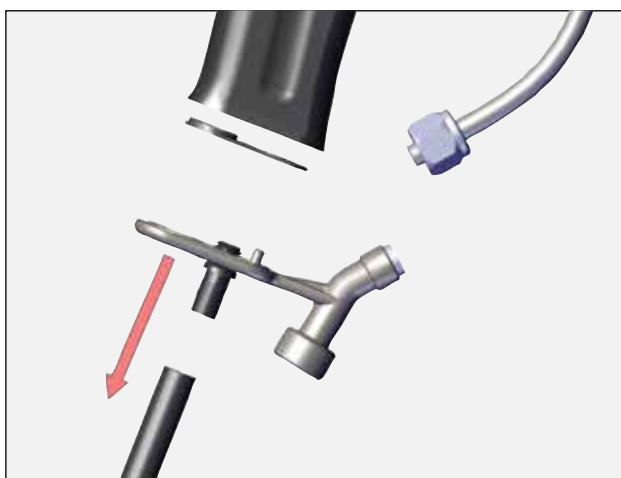

7. Install rear cover assembly.

8. Install trigger.

### Fluid Bracket Removal

1. Remove nut and ferrules.



4. Remove fittings and hose.

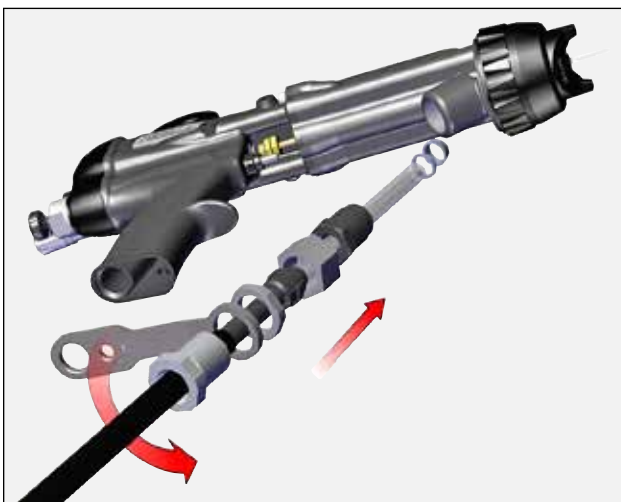



5. Re-install hose components.



6. Install gasket and bracket.

**NOTE**  
➤ This gasket is reusable. It should only be replaced if torn or damaged.



**Hose Cut Dimensions**

If the water base hose is serviced for any reason, the cut dimensions are shown below.

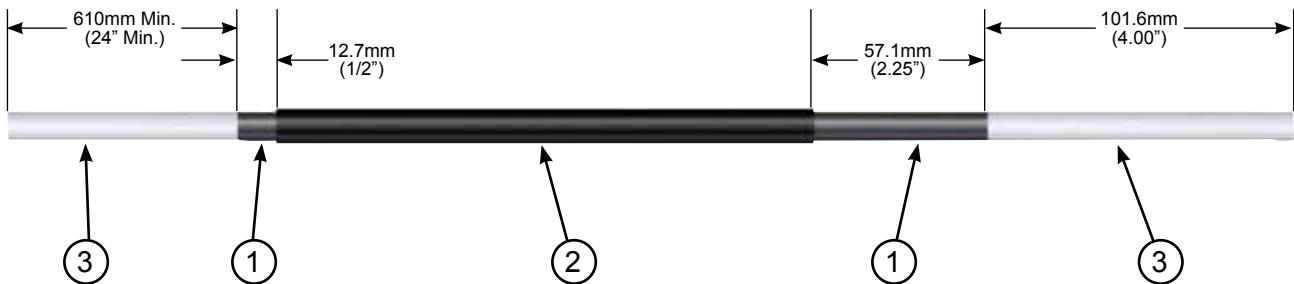

- 1. Conductive Sheath
- 2. Outer Jacket
- 3. Hose



### Gun Wrench Functions 80353-00

1. Adjust packings.

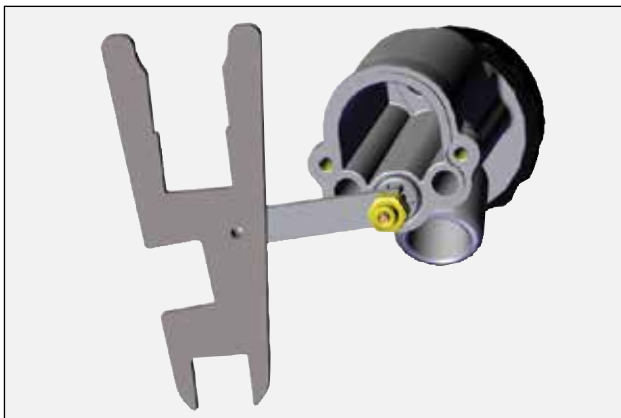

2. Remove nozzles

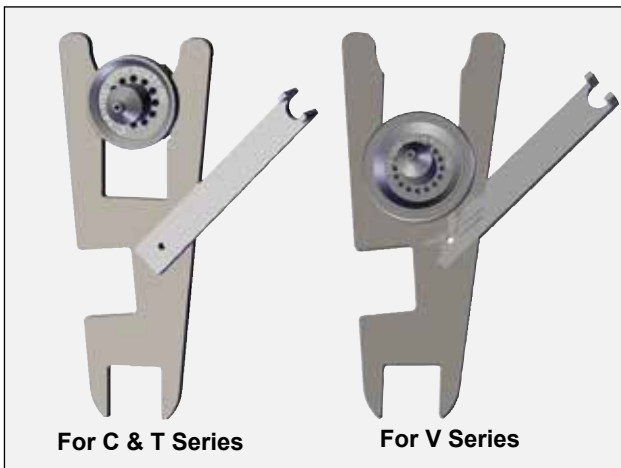

3. Air fitting.

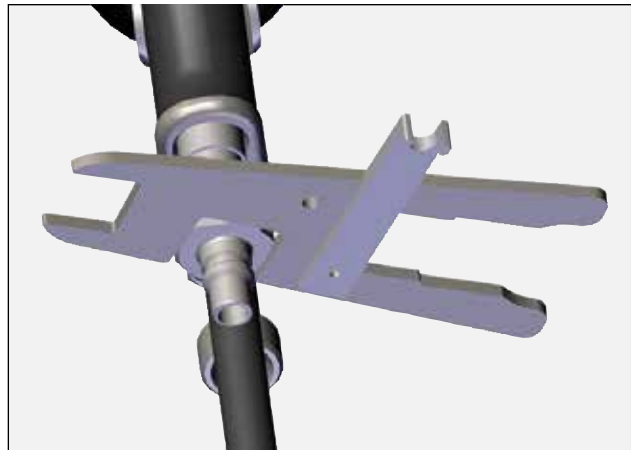

4. Remove rear cartridge.

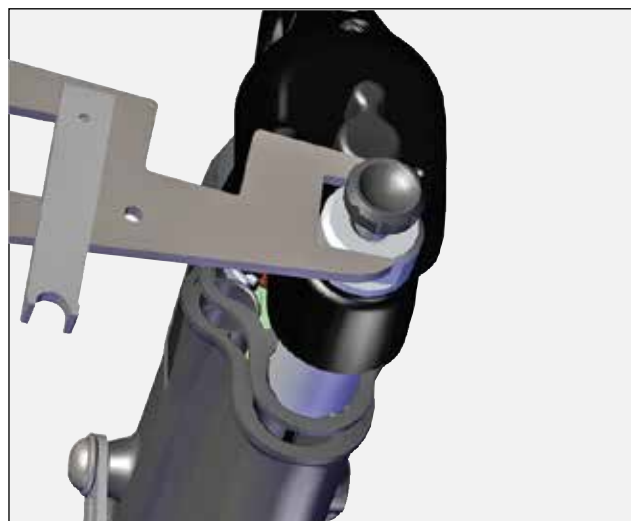



# TROUBLESHOOTING GUIDE



General Problem	Possible Cause	Solution
<b>ELECTRICAL</b>		
<b>No kV</b>	On-Off lever in wrong position	Ensure the On/Off lever is in the On position.
	Low pressure	Ensure 2.8 bar (40 psig) at the applicator handle with applicator triggered.
	No ground connection	Ensure the air hose is properly grounded to the earth ground.
	Cascade not functioning	Ensure cascade is functioning properly, swap parts as required.
	Failed motor function	Ensure motor is properly functioning.
	Too conductive paint	Ensure paint resistance > .1 Meg Ohm
<b>Low kV</b>	Fluid remnants in the air passage	a. Clean air passage with non-polar solvent. b. Ensure fluid nozzle is properly tightened.
	Wrong solvent used for final cleaning process.	Use non-polar solvent for the final cleaning process.
	Add sufficient air pressure at handle	Ensure 2.8 bar (40 psig) at the handle with applicator triggered.
<b>INADEQUATE DELIVERY</b>		
<b>No Fluid Flow</b>	No pressure	Ensure pressure at the fluid line at the applicator.
	Fluid tube may be plugged	Replace or clean.
	Fluid nozzle may be plugged	Replace or clean.
	Electrode not properly assembled	Reassemble tightened to stop.
	Material too viscous	Thin the material to a viscosity that is sprayable
<b>Spray Performance</b>	No adjustment of fan pattern	a. Restrictor missing. Insure restrictor is in place. b. Fluid nozzle tightened too tight. Tighten nozzle till it seats on the barrel o-ring then an additional 1/8 turn
	Poor atomization	Ensure atomization air passages are clear of all foreign particles.
	Fluid in air passages	Ensure fluid nozzle is properly tightened.
	Spits	Ensure air before fluid is properly adjusted.



# PARTS IDENTIFICATION

## RANSFLEX RFXw - DIRECT CHARGE WATER BASE

**81520 - ABC0EF**

Base  
Model No.

Optional  
Designations

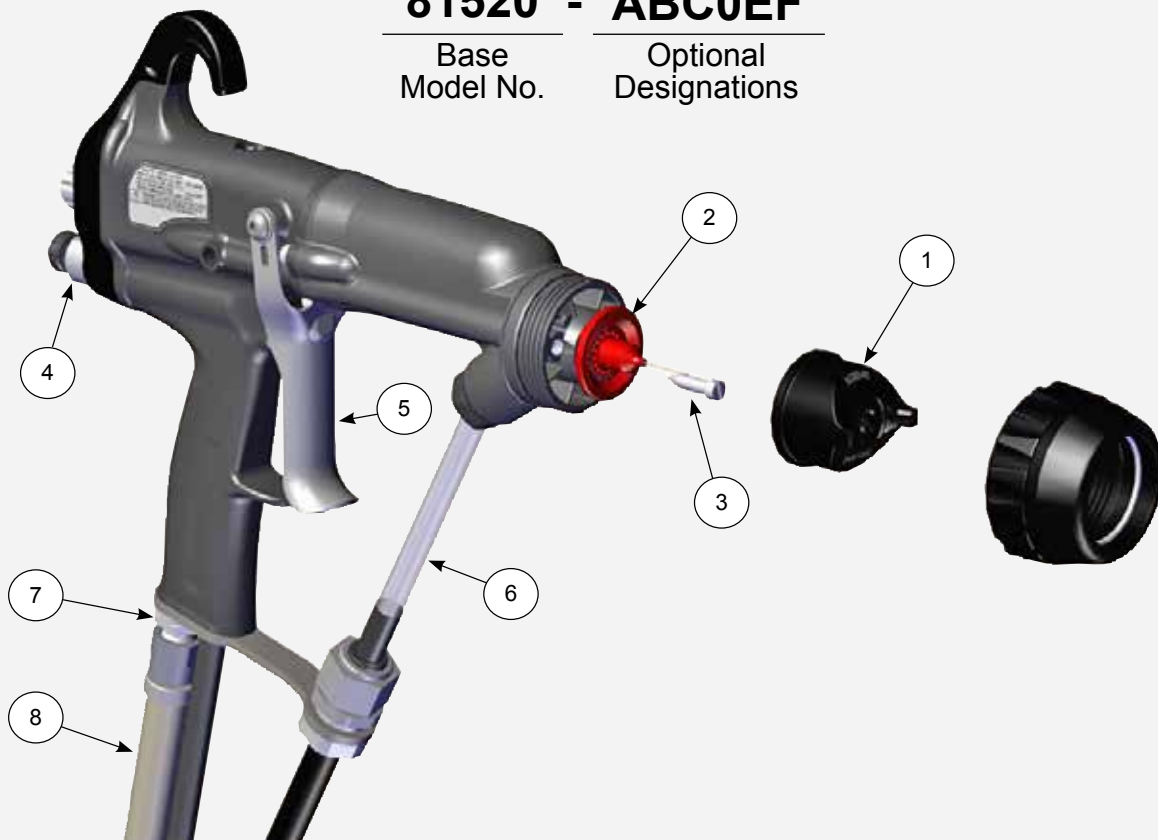

\* **NOTE:** All nozzles available in kits of 3.

### ATOMIZATION - TABLE OF "A" DASHES

"A" Dash No.	"A" Description	"1"	"2"	"3" / Color
0	V SERIES 1.2mm	80265-00	80264-12	79809-00 / YELLOW
1	V SERIES 1.4mm	80265-00	80264-14	79809-00 / YELLOW
2	V SERIES 1.8mm	80265-00	80264-18	79809-00 / YELLOW
3	C SERIES 1.2mm	80231-00	80230-12	79809-03 / WHITE
4	C SERIES 1.4mm	80231-00	80230-14	79809-03 / WHITE
5	C SERIES 1.8mm	80231-00	80230-18	79809-03 / WHITE
6	T SERIES 1.2mm	80240-00	80239-12	74963-05 / BLACK
7	T SERIES 1.4mm	80240-00	80239-14	74963-05 / BLACK
8	T SERIES 1.8mm	80240-00	80239-18	74963-05 / BLACK
9	ROUND SPRAY	79962-00	80400-00	74963-05 / BLACK

\* **NOTE:** All nozzles available in kits of 3.



### FLUID CONTROL - TABLE OF "B" DASHES

"B" Dash No.	"B" Description	"4"
1	ADJUSTABLE FLUID	80775-00
2	NON-ADJUSTABLE FLUID	80775-01

### TRIGGER - TABLE OF "C" DASHES

"C" Dash No.	"C" Description	"5"
1	2 FINGER TRIGGER	80211-00
2	4 FINGER TRIGGER	80386-00
3	2 FINGER SMALL PROFILE	80566-00

### FLUID HOSE - TABLE OF "E" DASHES

"E" Dash No.	"E" Description	"6"
0	NO FLUID HOSE	---
1	FLUID HOSE, 3/6" ID, 10m	80500-10
2	FLUID HOSE, 3/6" ID, 15m	80500-15
3	FLUID HOSE, 3/6" ID, 10m	80499-10
4	FLUID HOSE, 3/6" ID, 15m	80499-15

### AIR HOSE - TABLE OF "F" DASHES

"F" Dash No.	"F" Description	"7"	"8"
0	NO AIR HOSE, STANDARD	80868-00	---
1	STANDARD AIR HOSE, 5m	80868-00	80558-05
2	STANDARD AIR HOSE, 10m	80868-00	80558-10
3	STANDARD AIR HOSE, 15m	80868-00	80558-15
4	STANDARD AIR HOSE, 20m	80868-00	80558-20
5	NO AIR HOSE, QD	80869-00	---
6	QD AIR HOSE, 5m	80869-00	80558-06
7	QD AIR HOSE, 10m	80869-00	80558-11
8	QD AIR HOSE, 15m	80869-00	80558-16
9	QD AIR HOSE, 20m	80869-00	80558-21

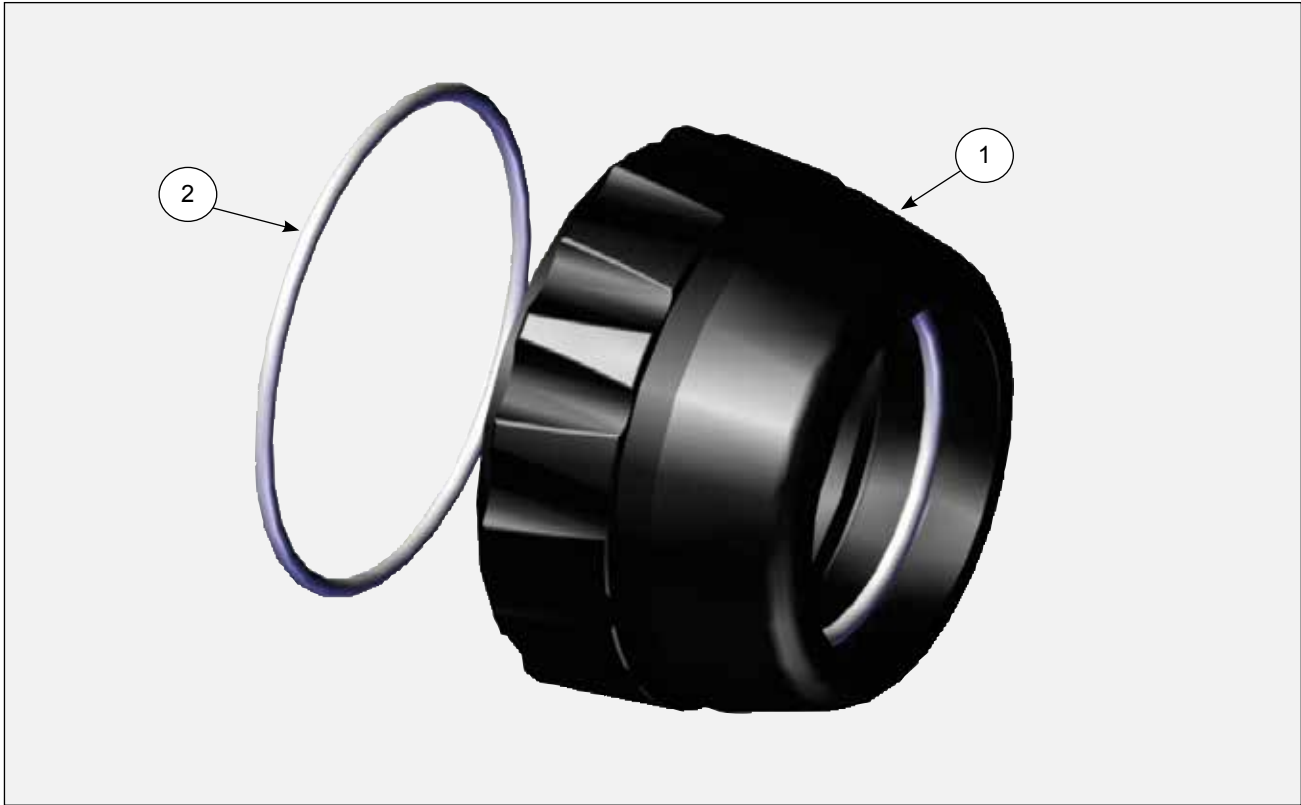

**RETAINING RING 80377-00**

Item No.	Part No.	Description	Qty.
1	80377-00	NUT, RETAINING & O-RING ASSEMBLY (CONTAINS ALL PARTS)	1
2	LSOR0005-17	O-RING, ENCAPSULATED	1

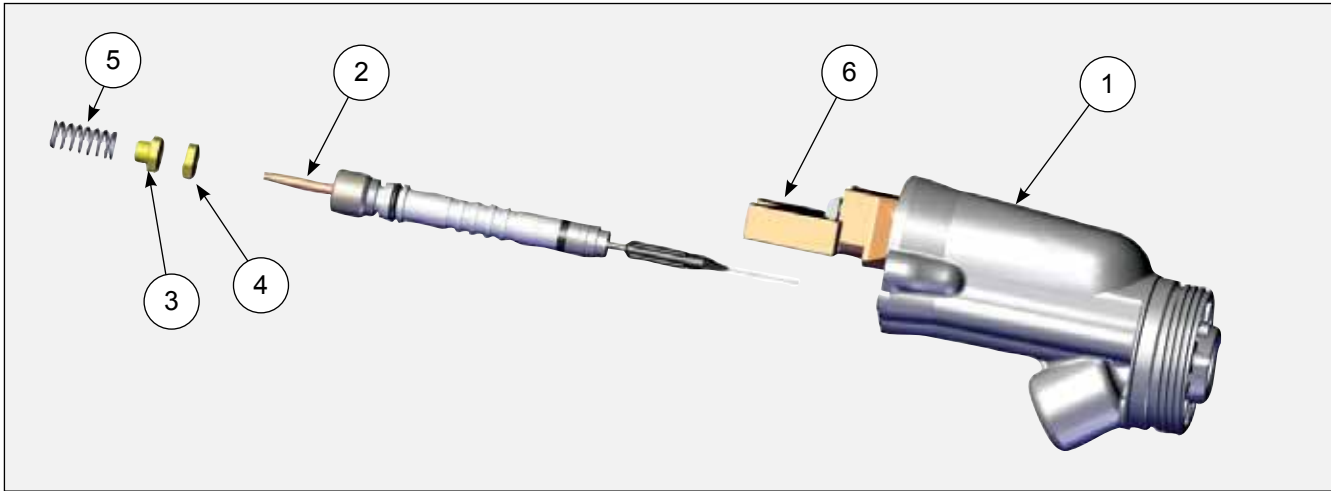

**RFXw 65kV BARREL**

Item No.	Part No.	Description	Qty.
1	80489-00	ASSEMBLY, BARREL & O-RING	1
2	80263-65	ASSEMBLY, NEEDLE SHAFT	1
3	80242-00	NUT, REAR JAM	1
4	80243-00	NUT, FRONT JAM	1
5	80258-00	SPRING, FLUID RETURN	1
6	80250-65	ASSEMBLY, CASCADE RFX (65 kV)	1

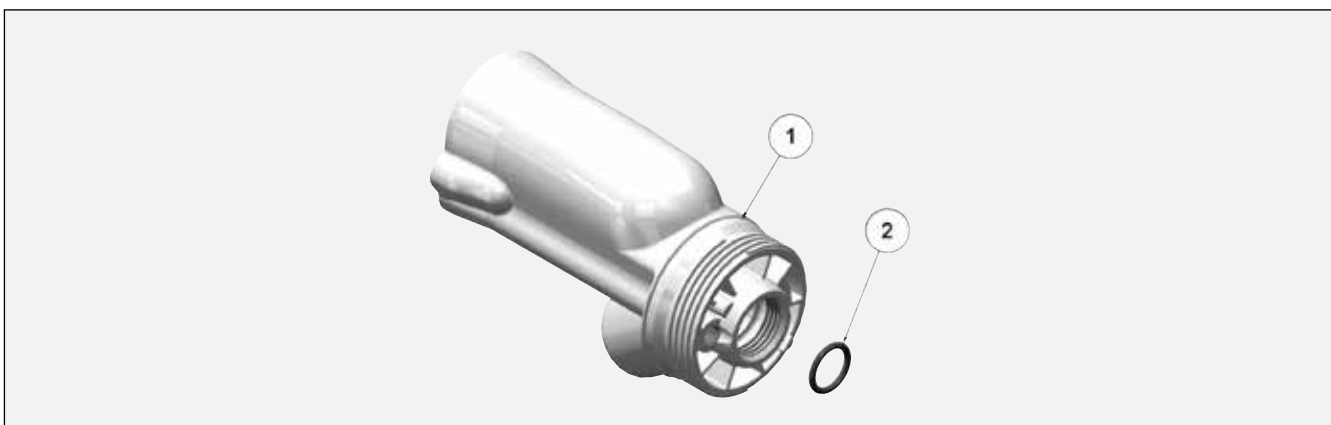

**RFXw 65kV BARREL AND O-RING P/N 80489-00**

Item No.	Part No.	Description	Qty.
1	80489-00	BARREL 65kV (INCLUDES O-RING)	1
2	79001-07	O-RING, SOLVENT PROOF	1

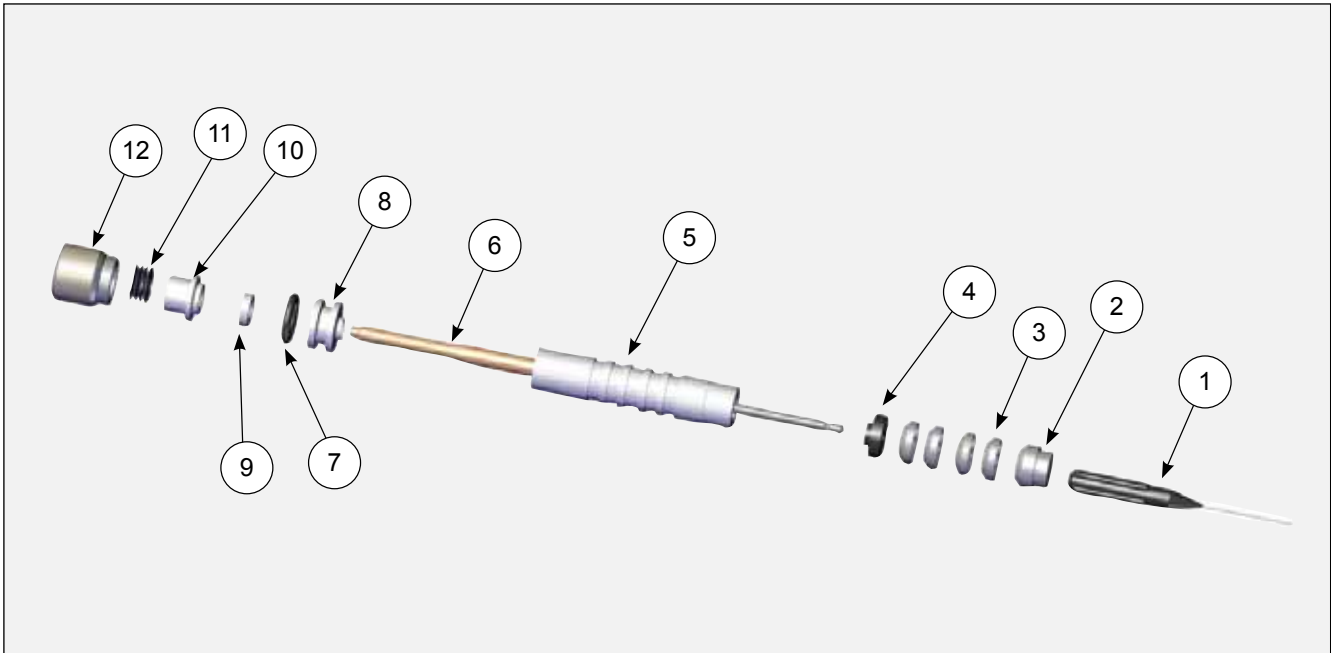

**RFXw 65kV NEEDLE SHAFT ASSEMBLY 80263-65**

Item No.	Part No.	Description	Qty.
1	70430-01	ASSEMBLY ELECTRODE, HIGH WEAR	1
2	80677-00	ADAPTER, MALE	1
3	14323-00	SEAL, CHEVRON, 3/8 DIA.	4
	14323-00-K4	SEAL, CHEVRON (KIT OF 4)	1
4	18821-00	ADAPTER-FEMALE-CHEVRON	1
5	80257-65	TUBE, PACKING	1
6	80225-65	NEEDLE SHAFT ASSEMBLY	1
7	79001-06	O-RING, SOLVENT PROOF	1
8	78629-00	RETAINER, NEEDLE SEAL, REAR	1
9	10051-05	CUP SEAL, SPRING LOADED	1
10	78630-00	SPACER, SEAL	1
11	17390-04	WASHER, SPRING, BELVILLE	6
	17390-04-K6	WASHER, SPRING, BEVILLE (KIT OF 6)	1
12	78631-00	NUT, PACKING	1



## HANDLE COMPONENTS FOR ALL MODELS

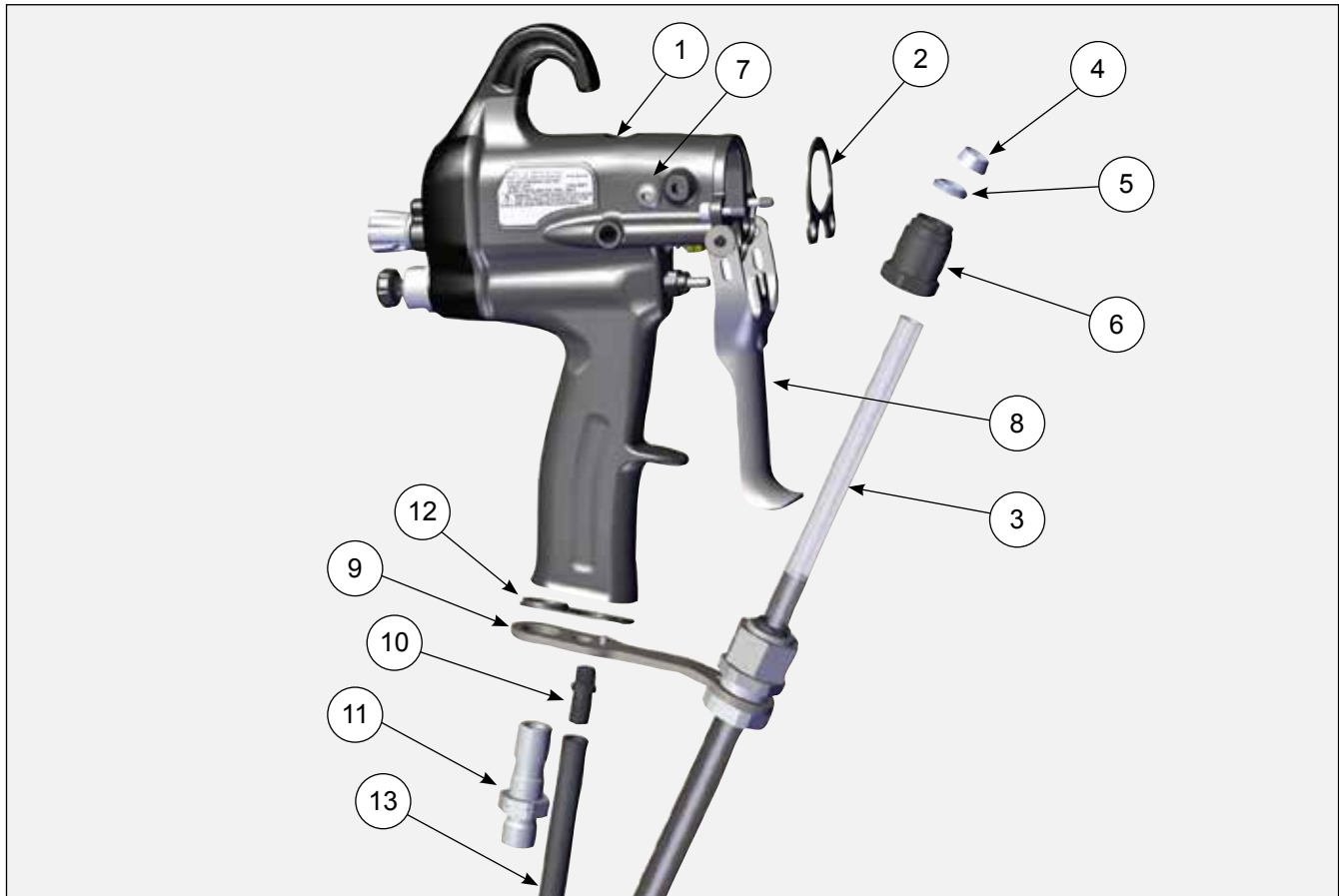

### HANDLE COMPONENTS - PARTS LIST

Item No.	Part No.	Description	Qty.
1	80775-00	INCLUDES HANDLE (80870-00) AND REAR COVER WITH MOTOR (80378-00) ASSEMBLY (ADJUSTABLE FLUID CONTROL)	1
	80775-01	INCLUDES HANDLE (80870-00) AND REAR COVER WITH MOTOR (80378-00) ASSEMBLY (NON-ADJUSTABLE FLUID CONTROL)	
2	80745-00	GASKET, BARREL	1
3	80500-XX	FLUID HOSE (WATER BASE), 3/16" ID	1
	80501-XX	FLUID HOSE (WATER BASE), 1/4" ID	
4	EMF-203-05	FERRULE, FRONT 1/4" - 05 IS P/N	1
5	EMF-202-05	FERRULE, BACK 1/4" - 05 IS P/N	1
6	80346-01	NUT, CONNECTOR, HOSE (WATER BASE)	1
7	80268-00	SCREW, TRIGGER	2
8	80211-00	ASSEMBLY, TRIGGER (SMALL PROFILE P/N 80566-00)	1
9	80497-00	BRACKET, FLUID	1
10	80221-00	FITTING, EXHAUST	1
11	80869-00	FITTING, AIR INLET,QD, LH THREAD	1
12	80684-00	GASKET, EXHAUST, COMBINED	1
13	79861-00	TUBING, EXHAUST	1

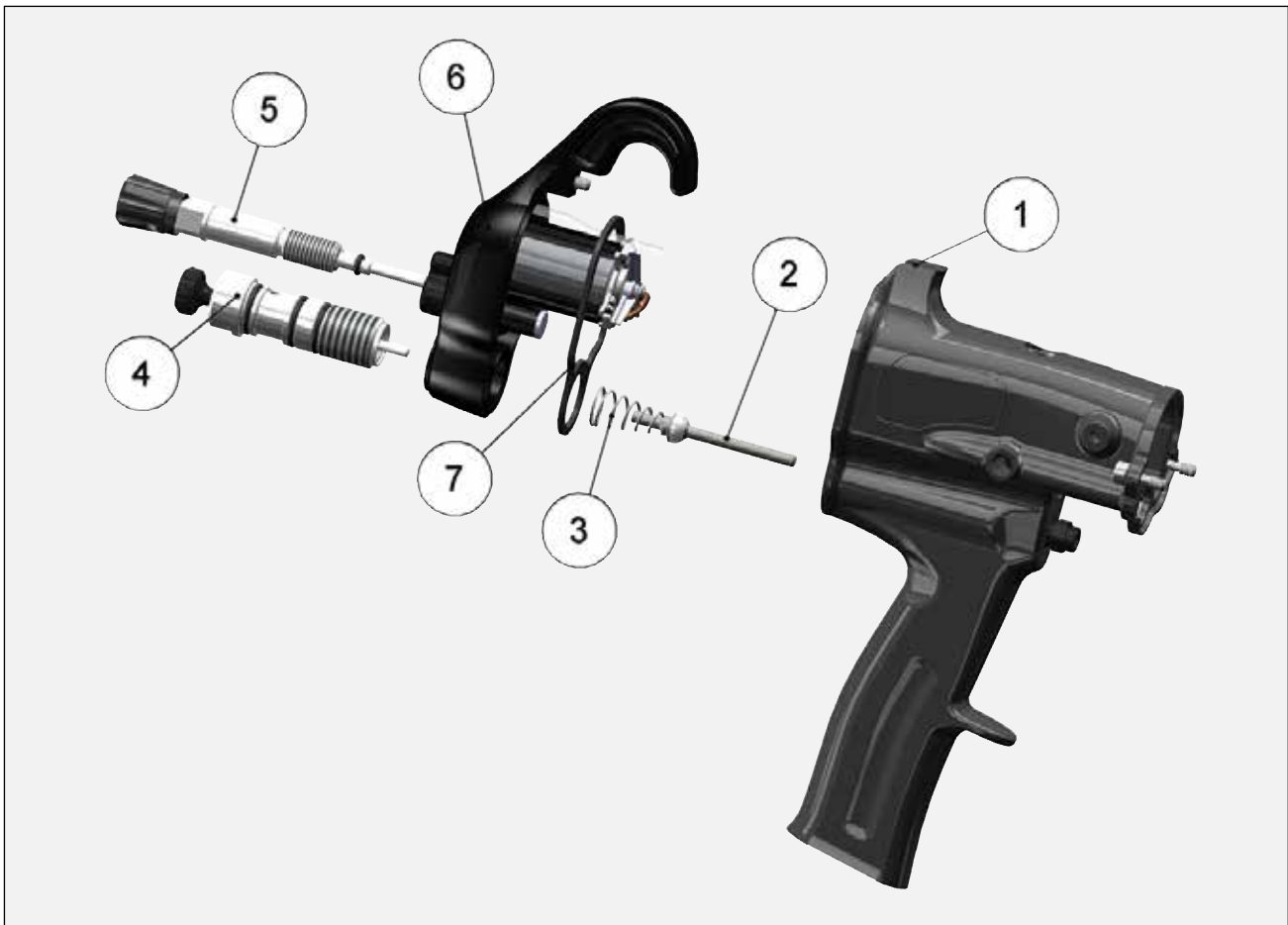

**HANDLE WITH REAR COVER WITH MOTOR 80775-00/01**

Item No.	Part No.	Description	Qty.
1	80870-00	ASSEMBLY, HANDLE	1
2	80244-00	ASSEMBLY, VALVE, AIR	1
3	80533-00	SPRING, AIR VALVE	1
4	80262-00	ASSEMBLY, VALVE, ADJUSTABLE FLUID CONTROL	1
	80262-01	ASSEMBLY, VALVE, NON-ADJUSTABLE FLUID CONTROL	1
5	80273-00	ASSEMBLY, VALVE FAN AIR	1
6	80378-00	REAR COVER AND MOTOR ASSEMBLY	1
7	80732-00	GASKET, REAR	1



**HANDLE ASSEMBLY 80870-00**

Item No.	Part No.	Description	Qty.
1	80870-00	ASSEMBLY, HANDLE INCLUDES ALL PARTS BELOW, MOTOR CONTROL BOARD AND HARNESSSES	1
2	80274-00	SCREW, BARREL-HANDLE	2
3	80229-00	NUT, RETAINING, AIR VALVE	1
4	10051-05	CUP SEAL, SPRING LOADED	1

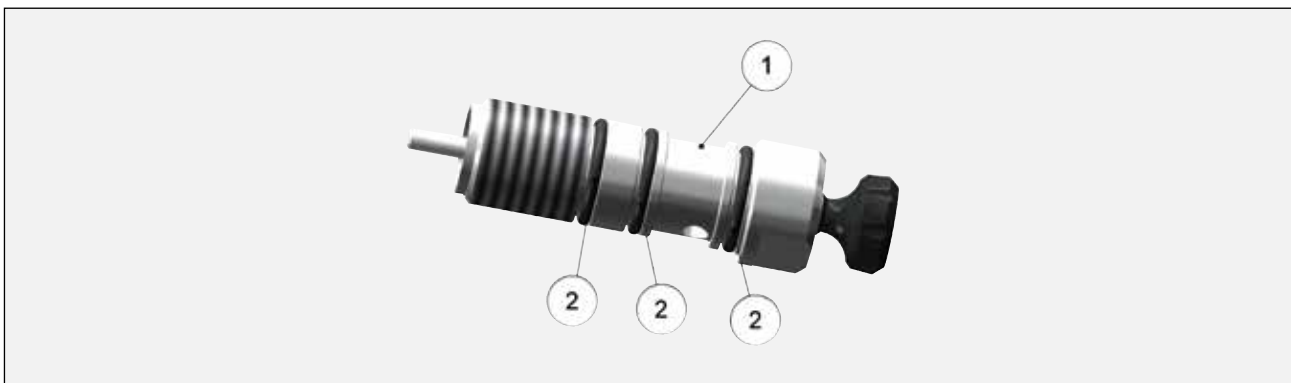

**REAR CARTRIDGE ASSEMBLY 80262-00 (ADJUSTABLE FLUID CONTROL)**

Item No.	Part No.	Description	Qty.
1	80262-00	ASSEMBLY, FLUID CARTRIDGE (INCLUDES ALL PARTS BELOW)	1
2	79001-08	O-RING, SOLVENT PROOF	3

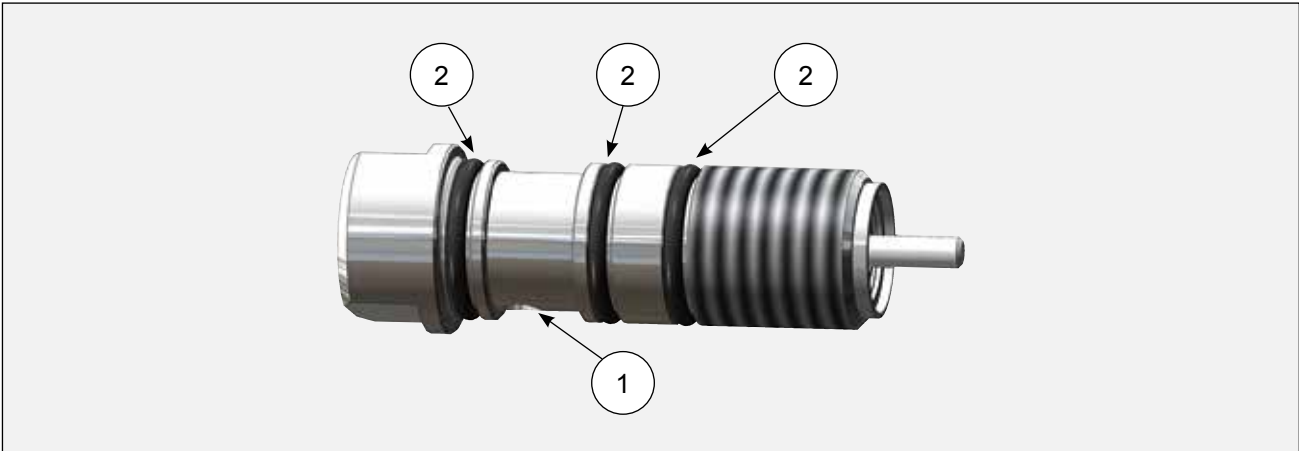

**REAR CARTRIDGE ASSEMBLY 80262-01 (NON-ADJUSTABLE FLUID CONTROL)**

Item No.	Part No.	Description	Qty.
1	80262-01	ASSEMBLY, FLUID CARTRIDGE (NON-ADJUSTABLE)	1
2	79001-08	O-RING, SOLVENT PROOF	3

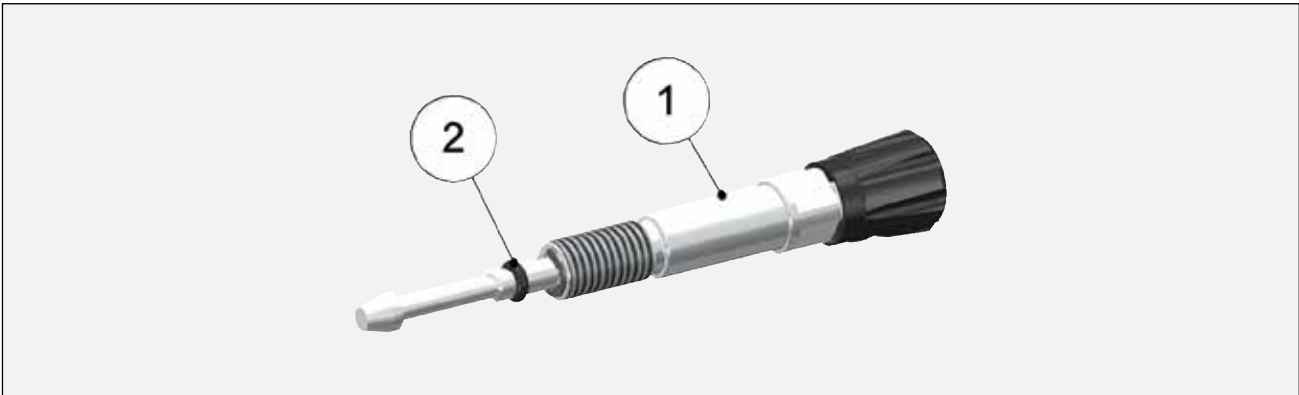

**80273-00 FAN AIR CARTRIDGE**

Item No.	Part No.	Description	Qty.
1	80273-00	ASS'Y., FAN VALVE (INCLUDES ALL PARTS BELOW)	1
2	79001-16	O-RING, SOLVENT PROOF	1



**80378-00 REAR COVER WITH MOTOR ASSEMBLY**

Item No.	Part No.	Description	Qty.
1	80378-00	COVER, REAR ASSEMBLY (INCLUDES ALL PARTS BELOW)	1
2	80213-00	PIPE, LIGHT	1
3	80255-00	ASSEMBLY, MOTOR	1
4	79775-00	BLOCK, PORTING	1
5	7554-61	O-RING, SOLVENT RESISTANT	1
6	80275-00	SCREW	1
7	80219-00	BRACKET, LOCKING	1

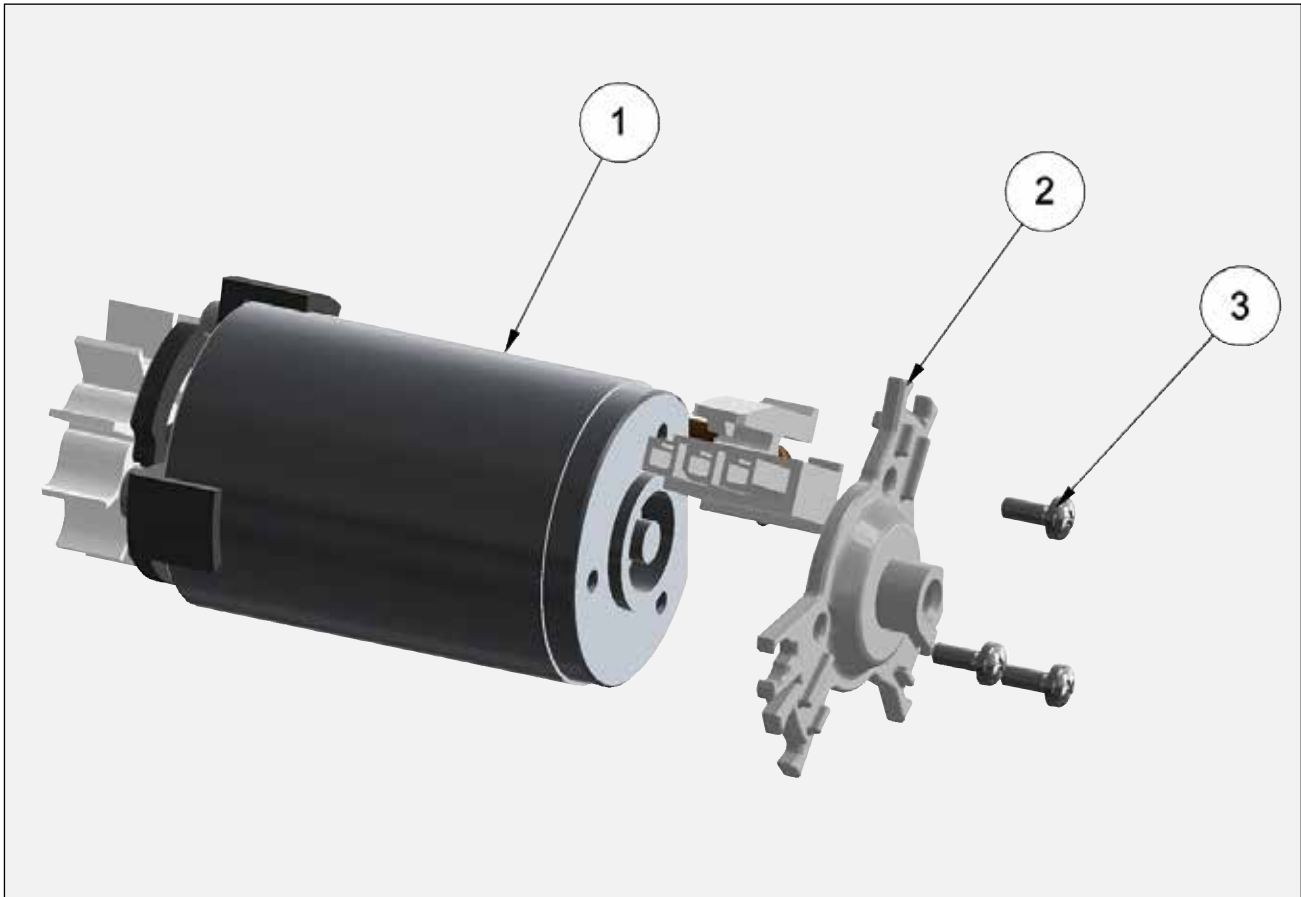

**80255-00 MOTOR ASSEMBLY**

Item No.	Part No.	Description	Qty.
1	80255-00	ASSEMBLY, MOTOR (INCLUDES ALL PARTS BELOW)	1
2	80217-00	COVER SUPPORT, MOTOR	1
3	79796-00	SCREW, MOTOR	3

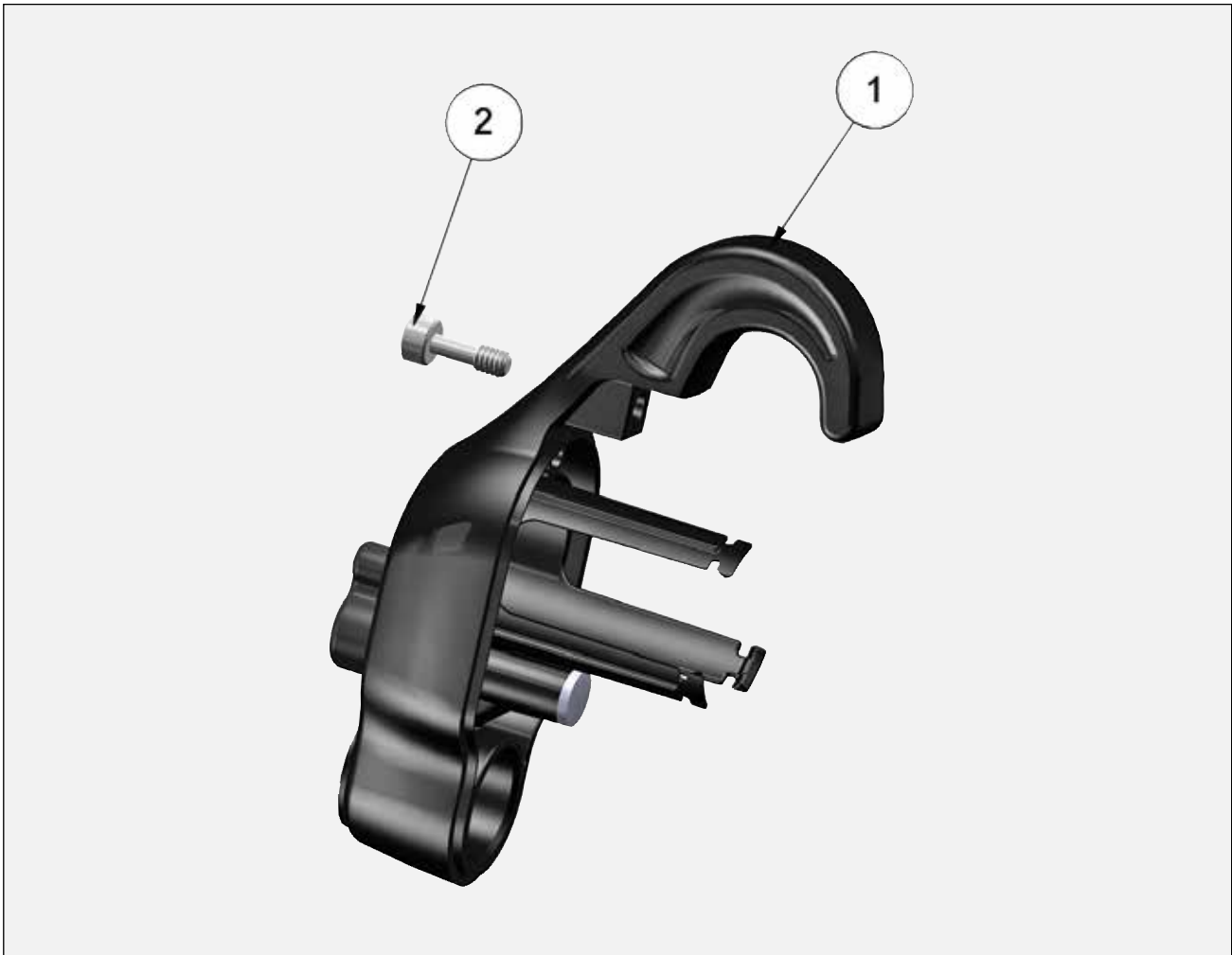

**80254-00 REAR COVER ASSEMBLY**

Item No.	Part No.	Description	Qty.
1	80254-00	COVER, REAR (CONTAINS PARTS BELOW)	1
2	80274-00	M4 X .7 SHCS	1

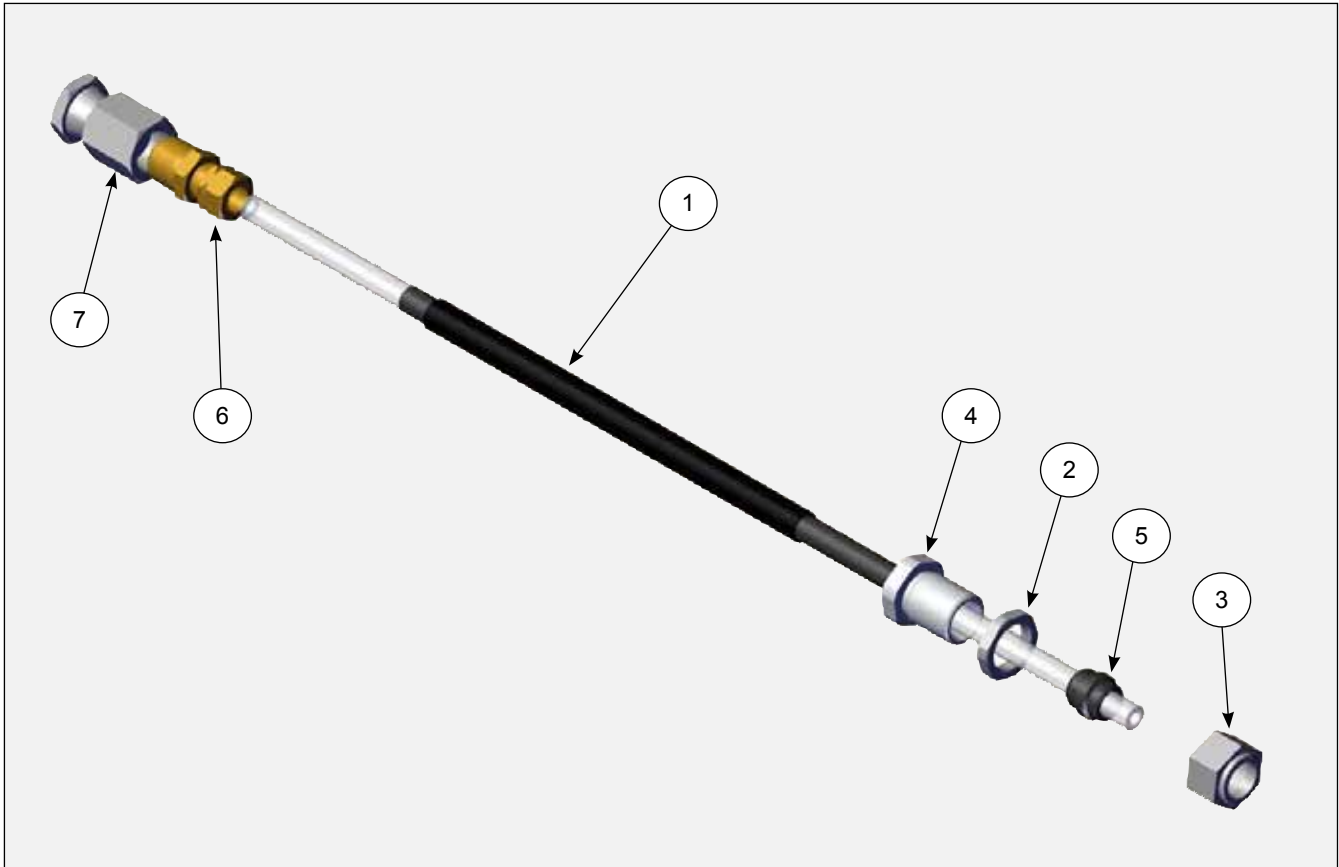

**WATER BASE HOSE ASSEMBLIES 80500-XX, 80501-XX**

Item No.	Part No.	Description	Qty.
1	80498-10	3/16" ID HOSE	1
	80498-15	3/16" ID HOSE	1
	80499-10	1/4" ID HOSE	1
	80499-15	1/4" ID HOSE	1
2	10553-05	NUT, SPECIAL	1
3	3587-02	NUT, NYLO-SEAL, TUBE FITTING	1
4	72310-00	BULKHEAD CONNECTOR ASSEMBLY	1
5	72315-00	FERRULE, CONDUCTOR	1
6	6241-06	CONNECTOR, MALE	1
7	7787-03	FTG STL FEMALE X FEMALE SVL PIPE	1



**79862-02 3mm Hex Driver**

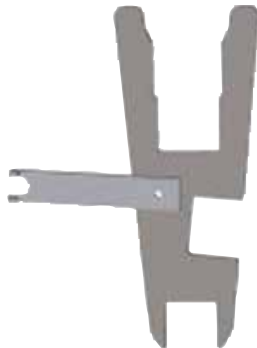

**80353-00 Gun Wrench**



**LSCH 0009 Grease**



**80395-00**

**ACCESSORIES INCLUDED WITH RFXw**

Part No.	Description
27141-081	Wrap, Spiral
59972-00	Pack of 4 LSCH0009 Grease
76102-00	Applicator Mounting Bracket
76652-01	HV Probe
76652-02	Spayability and SCI Paint Test Meter
76652-03	Paint Resistivity, Sprayability
76652-04	Deluxe Kit
80464-14	Nozzle, Fluid, High Wear for 80265-00 1.4 mm
80464-18	Nozzle, Fluid, High Wear for 80265-00 1.8 mm
80519-45	4.3mm (.170") ID Fluid Tube for 45 kV
80519-65	4.3mm (.170") ID Fluid Tube for 65 kV



**SPARE PARTS KITS**

Part No.	Description
79001-07-K3	Fluid inlet o-ring of barrels
80264-XX-K3	V Series nozzles in kits of 3 (XX = 12, 14 or 18)
80464-XX-K3	V Series high wear nozzles in kits of 3 (XX = 14, 18)
80230-XX-K3	C Series nozzles in kits of 3 (XX = 12, 14 or 18)
80239-XX-K3	T Series nozzles in kits of 3 (XX = 12, 14 or 18)
80401-65	V Series Atonization Kit - Contains (1) 80265-00 Air Cap, (2) 80264-14 Nozzle and (1) 79809-00 Restrictor
80401-40	T Series Atomization Kit - Contains (1) 80240-00 Air Cap, (2) 80239-14 Nozzle and (1) 74963-05 Restrictor
80401-31	C Series Atomization Kit - Contains (1) 80231-00 Air Cap, (2) 80230-14 Fluid Nozzle and (1) 79809-03 Restrictor
70430-01-K3	Resistive electrode in kits of 3
80696-00	Gasket kit contains gaskets for Rear Cover/Handle, Handle/Barrel and Handle fluid bracket.
80391-00	All soft parts required to rebuild an applicator
80395-K10	Gun Cover - Kit of 10
80395-K100	Gun Cover - Kit of 100
76633-K5	Conductive Gloves - Kit of 5
76633-K10	Conductive Gloves - Kit of 10
80507-00	Coiled Fluid Tube Kit



## RECOMMENDED SPARE PARTS

### RANSFLEX RECOMMENDED SPARE PARTS (Quantities Per Applicator)

Part #	Description	Qty
80264-XX	Nozzle, Fluid V Series (See page 42)	1
80264-XX-K3	Nozzle, Fluid V Series (See page 42) (Kit of 3)	1
80230-XX	Nozzle, Fluid C Series (See page 42)	1
80230-XX-K3	Nozzle, Fluid C Series (See page 42) (Kit of 3)	1
80239-XX	Nozzle, Fluid T Series (See page 42)	1
80239-XX-K3	Nozzle, Fluid T Series (See page 42) (Kit of 3)	1
80489-00	Assembly, Barrel (RFX Models) (with Front Seal)	1
80250-65	Cascade Assembly (RFX Models)	1
80745-00	Gasket, Barrel	1
80265-00	Air Cap V Series	2
80231-00	Air Cap C Series	2
80240-00	Air Cap T Series	2
80377-00	Nut, Retaining, Air Nozzle	1
EMF-201-04	Nut, Hex Nylon	2
EMF-202-04	Ferrule, Back	2
EMF-203-04	Ferrule, Front	2
80268-00	Screw, Trigger Retention	2
80242-00	Nut, Rear, Jam	1
80243-00	Nut, Fluid Jam, Front	1
80255-00	Assembly, Motor	1
80258-00	Spring, Fluid Return	1
70430-01	Electrode	2
70430-01-K3	Kit of 3 Electrodes	1
80732-00	Gasket, Rear	1
80263-65	Shaft Assembly	1
10051-05	Seal, Air Valve	1
80684-00	Gasket, Exhaust, Combined	1
LSCH0009-00	Dielectric Grease	2
80259-00	Spring, Air Valve	1

## **WARRANTY POLICY**

Ransburg products are covered by Carlisle Fluid Technologies materials and workmanship limited warranty. The use of any parts or accessories, from a source other than Carlisle Fluid Technologies, will void all warranties. For specific warranty information please refer to the warranty document supplied with your product, call our Technical Support, or contact your distributor.

### **Technical Support**

Tel (toll free): 800-233-3366 Fax: 419-470-2233

Technical Support will direct you to the appropriate telephone number for ordering Spare Parts.

Carlisle Fluid Technologies reserves the right to modify equipment specifications without prior notice. DeVilbiss®, Ransburg®, ms®, BGK®, and Ransburg® are registered trademarks of Carlisle Fluid Technologies, Inc.

©2017 Carlisle Fluid Technologies, Inc.  
All rights reserved.

---

Ransburg is part of Carlisle Fluid Technologies, a global leader in innovative finishing technologies. For technical assistance or to locate an authorized distributor, contact one of our international sales and customer support locations.

For the latest information about our products, visit [www.carlisleft.com](http://www.carlisleft.com).